

Encoders without bearings - incremental

Magnetic sensing, through hollow shaft max. $\varnothing 80$ mm

64...4096 pulses or 64 sinewave cycles per turn

MHGE 100 - HDmag

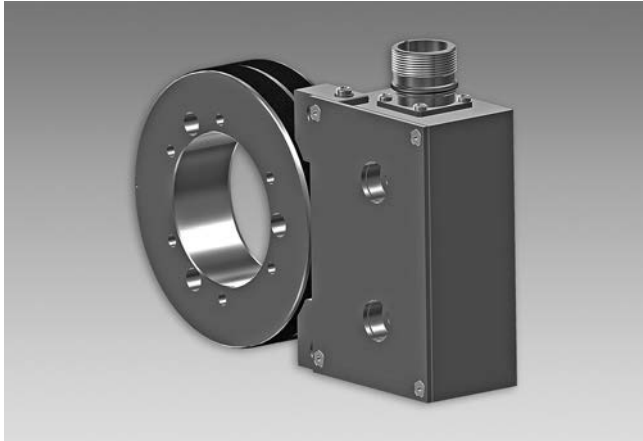

MHGE 100 - Version for axial screw mounting

Technical data - electrical ratings

Interference immunity	EN 61000-6-2
Emitted interference	EN 61000-6-3
Approvals	CE, UL approval / E217823, Option: DNV approval

Technical data - electrical ratings (square-wave)

Voltage supply	4.75...30 VDC
Consumption w/o load	≤ 70 mA
Pulses per revolution	64...4096
Phase shift	$90^\circ \pm 10^\circ$
Duty cycle	40...60 %
Reference signal	Zero pulse, width 90°
Sensing method	Magnetic
Output frequency	≤ 300 kHz
Output signals	A+, B+, R+, A-, B-, R-
Output stages	HTL TTL/RS422

Technical data - electrical ratings (SinCos)

Voltage supply	5 VDC
Consumption w/o load	≤ 70 mA
Sinewave cycles per revolution	64
Phase shift	$90^\circ \pm 5^\circ$
Reference signal	Zero pulse, width 90°
Sensing method	Magnetic
Output signals	A+, B+, R+, A-, B-, R-
Output stages	SinCos 1 Vpp
Difference of SinCos amplitude	≤ 20 mV
Harmonics typ.	-40 dB
DC offset	≤ 20 mV

Features

- Robust and wearless
- High protection through fully encapsulated electronics
- Large tolerances: axial ± 3 mm, radial max. 2.2 mm
- Very compact dimensions
- Simple mounting, easy adaptation

Optional

- DNV approval on request
- Redundant sensing head on request
- Increased operating speed through triple-bandage
- Offshore version

Technical data - mechanical design

Sensor head	Standard signal processing
Size (flange)	$\varnothing 99,9$ mm
Shaft type	$\varnothing 16...80$ mm (through hollow shaft)
Axial tolerance	± 3 mm (wheel/head)
Radial tolerance	0.1...2.2 mm (wheel/head)
Protection DIN EN 60529	IP 67 (head), IP 68 (wheel)
Operating speed	≤ 8000 rpm
Materials	Housing sensing head: aluminium alloy Wheel: stainless steel (1.4104, option DNV: 1.4313) Wheel: galvanized steel (version stainless)
Operating temperature	$-40...+100$ °C
Resistance	IEC 60068-2-6 Vibration 30 g, 55-2000 Hz IEC 60068-2-27 Shock 300 g, 2 ms
Accuracy of magnetic measure	± 300 "
Connection	Flange connector M23, 12-pin Terminal box

Encoders without bearings - incremental

Magnetic sensing, through hollow shaft max. $\varnothing 80$ mm

64...4096 pulses or 64 sinewave cycles per turn

MHGE 100 - HDmag

Part number

MHGE 100

	5			N		
--	---	--	--	---	--	--

Connection

- C 1x flange connector M23, tangential 12-pin, male, CCW
- B 1x terminal box with cable gland M20, radial

Pulse number/sinewave cycles - see table

Voltage supply / signals

- S 5 VDC / SinCos
- R 4,75...30 VDC / square-wave (TTL)
- T 5 VDC $\pm 5\%$ / square-wave (TTL)
- H 10...30 VDC / square-wave (HTL)
- U 5...30 VDC / square-wave (5 VDC = TTL / 10...30 VDC = HTL universal)

Mounting type / hollow shaft (\varnothing mm)

Screw or shrink fit mounting

G38, G45, G50, G55, G60, G65, G70, G75, G80

Clamping set mounting

Z16, Z20, Z22, Z25, Z28, Z32, Z35, Z38, Z40, Z42, Z45, Z48, Z50, Z55, Z60, Z63, Z65

Clamping set mounting stainless

Y16, Y20, Y22, Y25, Y28, Y32, Y35, Y38, Y40, Y42, Y45, Y48, Y50, Y55, Y60, Y63, Y65

Clamping ring mounting

K25, K30, K32, K38, K40, K45, K48, K50, K55, K56, K60, K65, K70, K75

Bandaging

B Encoder wheel standard bandage

T Encoder wheel with triple-bandage

Pulse number/sinewave cycles

64	256	1024	4096
128	512	2048	

Sinewave cycles only 64 at SinCos output.

Accessories

Connectors and cables

HEK 8 Sensor cable for encoders

Encoders without bearings - incremental

Magnetic sensing, through hollow shaft max. $\varnothing 80$ mm

64...4096 pulses or 64 sinewave cycles per turn

MHGE 100 - HDmag

Output signals

Version with square-wave signals HTL oder TTL at positive rotating direction

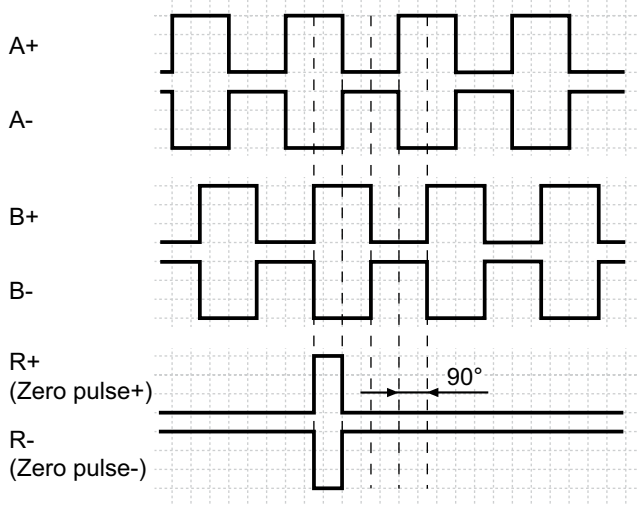

Version with SinCos signals at positive rotating direction

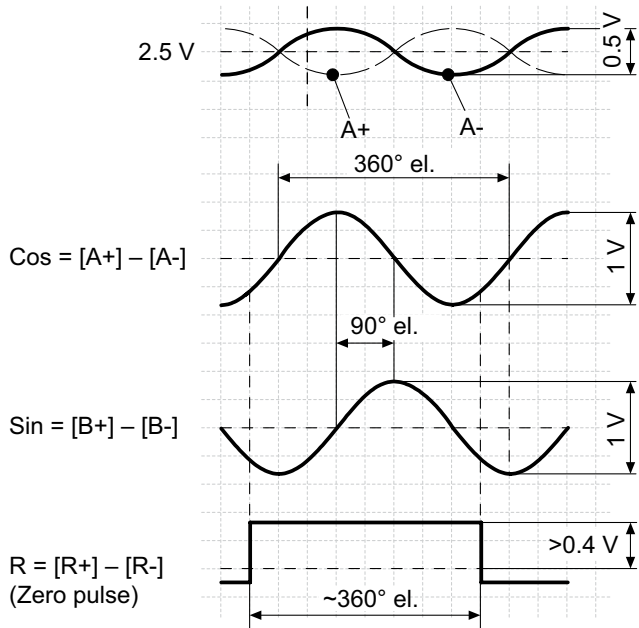

Terminal assignment

View A

Flange connector M23, 12-pin, male contacts, CCW

Pin	Assignment
1	B-
2	Do not use
3	R+ (Zero pulse)
4	R- (Zero pulse inv.)
5	A+
6	A-
7	Do not use
8	B+
9	Do not use
10	⊥
11	Do not use
12	+UB

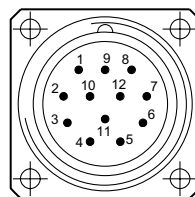

View B

Connecting terminal terminal box

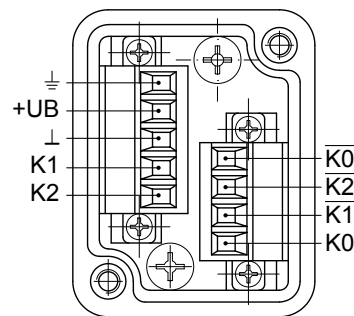

Encoders without bearings - incremental

Magnetic sensing, through hollow shaft max. $\varnothing 80$ mm

64...4096 pulses or 64 sinewave cycles per turn

MHGE 100 - HDmag

Dimensions

Version for axial screw mounting or shrink fit mounting

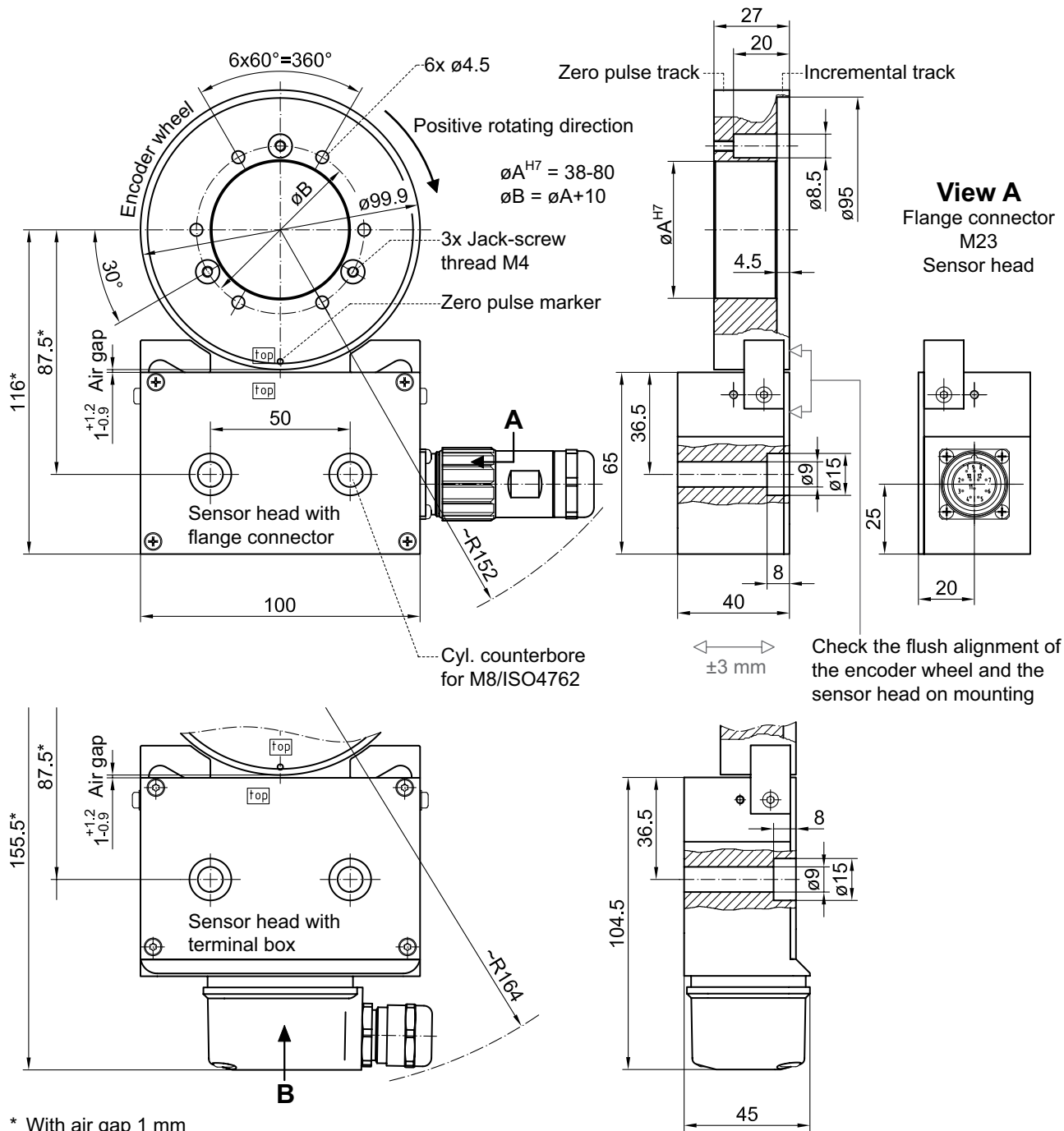

* With air gap 1 mm

Encoders without bearings - incremental

Magnetic sensing, through hollow shaft max. $\varnothing 80$ mm

64...4096 pulses or 64 sinewave cycles per turn

MHGE 100 - HDmag

Dimensions

Version for clamping set mounting

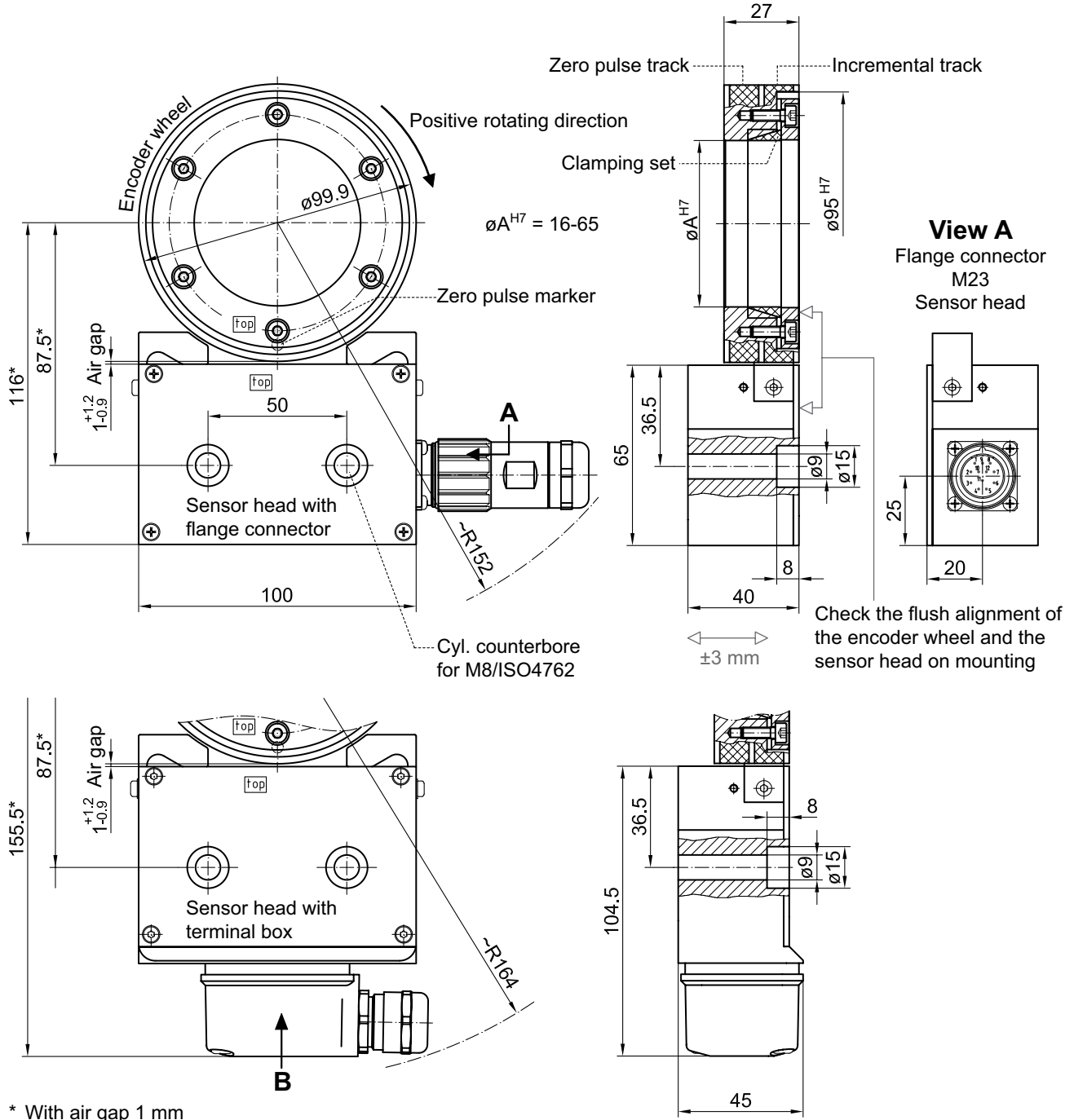

Encoders without bearings - incremental

Magnetic sensing, through hollow shaft max. $\varnothing 80$ mm

64...4096 pulses or 64 sinewave cycles per turn

MHGE 100 - HDmag

Dimensions

Version for clamping ring mounting

