

MLG-2 Prime

Measuring automation light grid

SICK
Sensor Intelligence.



Described product

MLG-2 Prime

Manufacturer

SICK AG
Erwin-Sick-Str. 1
79183 Waldkirch
Germany

Legal information

This work is protected by copyright. Any rights derived from the copyright shall be reserved for SICK AG. Reproduction of this document or parts of this document is only permissible within the limits of the legal determination of Copyright Law. Any modification, abridgment or translation of this document is prohibited without the express written permission of SICK AG.

The trademarks stated in this document are the property of their respective owner.

© SICK AG. All rights reserved.

Original document

This document is an original document of SICK AG.



Contents

1	About this document.....	6
1.1	Purpose of this document.....	6
1.2	Scope.....	6
1.3	Target group.....	6
1.4	Information depth.....	6
1.5	Symbols used.....	6
1.6	Abbreviations used.....	7
2	Safety information.....	8
2.1	Requirements for the qualification of personnel.....	8
2.2	Correct use.....	8
2.3	General safety notes.....	9
3	Product description.....	10
3.1	Type labels of the MLG-2 Prime.....	10
3.2	Type code of the MLG-2 Prime.....	10
3.2.1	MLG-2 Prime monitoring height.....	11
3.2.2	Combinations of MLG-2 Prime inputs and outputs.....	11
3.2.3	MLG-2 Prime sensing range and minimum detectable object length.....	12
3.2.4	MLG-2 Prime preconfigurations.....	12
3.3	MLG-2 Prime product properties.....	13
3.4	Setup and function.....	13
3.4.1	MLG-2 Prime device components.....	14
3.4.2	Measurement principle.....	14
3.4.3	MLG-2 Prime synchronization.....	15
3.4.4	Detection height.....	15
3.4.5	Teach-in.....	16
3.4.6	Beam blanking.....	16
3.4.7	Sensing ranges.....	17
3.5	Scan time.....	18
3.5.1	MLG-2 Prime response time and minimum presence time..	19
3.5.2	Scan time with cross-beam function.....	19
3.6	Beam separation and minimum detectable object.....	19
3.6.1	Minimum detectable object with parallel-beam function....	19
3.6.2	Minimum detectable object length.....	20
3.6.3	Minimum detectable object with cross-beam function	20
3.7	Operating reserve.....	21
3.8	Interfaces.....	22
3.8.1	Preliminary evaluation.....	22
3.8.2	Configurable applications of the MLG-2 Prime.....	22
3.9	Display and operating elements.....	22
3.9.1	Sender.....	22
3.9.2	Receiver	23

3.10	Inputs.....	25
3.10.1	Switching input on the MLG-2 Prime receiver.....	25
3.10.2	Test input on the sender.....	25
3.11	Application examples.....	25
3.11.1	Application examples for the MLG2 Prime.....	25
4	Mounting.....	26
4.1	Scope of delivery.....	26
4.2	Recommended mounting arrangements.....	26
4.2.1	Mounting with light in opposite directions.....	26
4.2.2	Mounting with light in the same direction.....	27
4.2.3	Minimum distance from reflective surfaces.....	28
4.3	Mounting procedure.....	29
4.3.1	Mounting the QuickFix bracket.....	30
4.3.2	Mounting the FlexFix bracket.....	31
5	Electrical installation.....	33
5.1	Connections of the MLG-2 Prime.....	33
6	Commissioning.....	35
6.1	Mechanical alignment of sender and receiver.....	35
6.2	Alignment and teach-in.....	36
6.2.1	MLG-2 Prime.....	36
7	Operating the MLG2 Prime.....	38
7.1	Configuration with the control panel.....	38
7.1.1	Basic operation.....	38
7.1.2	Setting the application for switching outputs.....	40
7.1.3	Setting the application for analog outputs and switching output.....	41
7.1.4	System settings on operating level 2.....	42
7.2	Measuring functions.....	43
7.2.1	Applications for switching outputs.....	43
7.2.2	Applications for analog outputs.....	44
7.2.3	System settings on operating level 2.....	46
8	IO-Link.....	48
8.1	Configuration via acyclic service data.....	48
8.2	Data storage (IO-Link).....	48
8.3	Output of process data from the MLG-2 Prime.....	48
9	Servicing.....	49
10	Troubleshooting.....	50
10.1	Response to faults.....	50
10.2	SICK support.....	50
10.3	LED indicators and error indicators.....	50

11	Decommissioning.....	51
11.1	Disposal.....	51
11.2	Returns.....	51
12	Technical data.....	52
12.1	Data sheet.....	52
12.2	Diagrams.....	54
12.2.1	MLG-2 Prime response time and minimum presence time..	54
12.3	Dimensional drawings.....	55
12.3.1	MLG-2 Prime dimensional drawing.....	55
12.3.2	Measurement tables.....	56
13	Ordering information.....	57
14	Accessories.....	58
15	Annex.....	60
15.1	Compliance with EU directive.....	60
16	List of figures.....	61
17	List of tables.....	62

1 About this document

1.1 Purpose of this document

These operating instructions are for giving technical personnel of the machine manufacturer or operator instructions on the mounting, configuration, electrical installation, commissioning, operation, and maintenance of the MLG-2 measuring automation light grid.

These operating instructions do not provide information on operating the machine into which a measuring automation light grid is integrated. For information about this, refer to the operating instructions of the particular machine.

1.2 Scope

These operating instructions are valid for the MLG-2 Prime measuring automation light grid.

1.3 Target group

These operating instructions are intended for planning engineers, developers, and operators of plants and systems into which one or more MLG-2 measuring automation light grids are to be integrated. They are also intended for people who integrate the MLG-2 into a machine, carry out its commissioning, or who are in charge of maintenance.

1.4 Information depth

These operating instructions contain information about the MLG-2 measuring automation light grid on the following topics:

- Mounting
- Electrical installation
- Commissioning and configuration
- Care
- Fault diagnosis
- Part numbers
- Conformity and approval

When planning and using a measuring automation light grid such as the MLG-2, technical skills are required that are not covered by this document.

The official and legal regulations for operating the MLG-2 must always be complied with.



NOTE

Please also refer to the SICK AG website: www.sick.de.

1.5 Symbols used

Recommendation

Recommendations are designed to assist you in the decision-making process with respect to the use of a certain function or a technical measure.



NOTE

Notes inform you about special aspects of the device.



LED symbols describe the status of a diagnostics LED. Examples:

- The LED is illuminated continuously.
- ◐ The LED flashes evenly.
- ◑ The LED flashes briefly.
- The LED is off.

▶ Take action ...

Instructions for taking action are indicated by an arrow. Carefully read and follow the instructions for action.





CAUTION Warning!

A warning indicates a specific or potential hazard. This is intended to protect you against accidents.

Read carefully and follow the warnings!

Sender and receiver

In figures and connection diagrams, the symbol  indicates the sender and  indicates the receiver.

1.6 Abbreviations used

FBB	First Beam Blocked
LBB	Last Beam Blocked
MDA	Minimum Detectable Absorption
MDO	Minimum Detectable Object
MLG-2	Measuring automation light grid 2
MOL	Minimum Detectable Object Length
MSB	Most Significant Bit
NBB	Number of Beams Blocked
PLC	Programmable logic controller

2 Safety information

2.1 Requirements for the qualification of personnel

The MLG-2 measuring automation light grid must only be mounted, commissioned, and maintained by authorized personnel.



NOTE

Repair work on the MLG-2 may only be performed by qualified and authorized service personnel from SICK AG.

The following qualifications are necessary for the various tasks:

Task	Qualification
Mounting	<ul style="list-style-type: none"> • Basic practical technical training • Knowledge of the current safety regulations in the work-place
Electrical installation and device replacement	<ul style="list-style-type: none"> • Practical electrical training • Knowledge of current electrical safety regulations • Knowledge of the operation and control of the devices in their particular application (e. g., industrial robots, storage and conveyor systems)
Commissioning, operation, and configuration	<ul style="list-style-type: none"> • Knowledge of the current safety regulations and of the operation and control of the devices in their particular application • Knowledge of automation systems • Knowledge of how to use automation software

Table 1: Authorized personnel

2.2 Correct use

The MLG-2 measuring automation light grid is a measuring device which is manufactured according to the recognized industrial regulations and which meets the quality requirements stipulated in ISO 9001:2008 as well as those relating to environmental management systems as defined in ISO 14001:2009.

The measuring automation light grids are solely intended for the optical and non-contact detection of objects, animals, and persons.

A measuring automation light grid is designed for mounting and may only be operated according to its intended function. For this reason, it is not equipped with direct safety devices.

The system designer must provide measures to ensure the safety of persons and systems in accordance with the legal guidelines.

In the event of any other usage or modification to the MLG-2 measuring automation light grid (e.g., due to opening the housing during mounting and electrical installation) or in the event of changes made to the SICK software, any claims against SICK AG under the warranty will be rendered void.

Foreseeable misuse

The MLG-2 is **not** suitable for the following applications, among others:

- As a safety device to protect persons, their hands, or other body parts
- Under water

- In explosive environments
- Outdoors, without additional protection

2.3 General safety notes



CAUTION

Observe the following to ensure the safe use of the MLG-2 as intended.

The measuring automation light grid must be installed and maintained by trained, qualified personnel with knowledge of electronics, precision engineering, and control programming. The relevant technical safety standards must be observed.

All persons entrusted with the installation, operation, or maintenance of the devices must follow the safety guidelines:

- The operating instructions must always be available and must be followed.
 - Unqualified personnel must stay away from the system during installation and maintenance.
 - The system must be installed in accordance with the applicable safety regulations and mounting instructions.
 - The work safety regulations of the employers' liability insurance associations and trade associations in the respective country must be observed during installation.
 - Failure to observe the relevant work safety regulations may lead to physical injury or cause damage to the system.
-

3 Product description

3.1 Type labels of the MLG-2 Prime

The MLG-2 senders and receivers each have a type label.

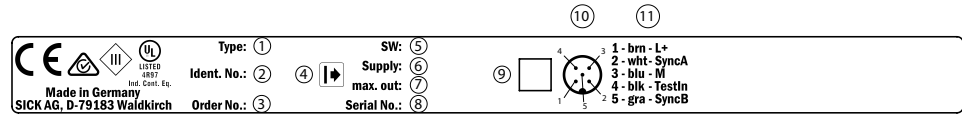

Figure 1: Type label of sender

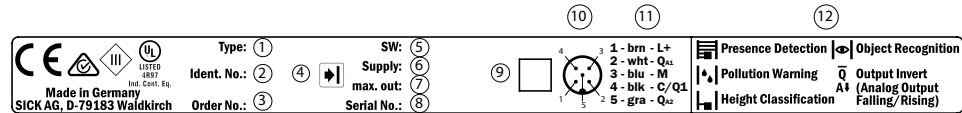

Figure 2: Type label of receiver

- ① Type code
- ② Part number for the individual sender or receiver
- ③ Part number of the entire MLG-2
- ④ Receiver or sender symbol
- ⑤ Firmware version
- ⑥ Required power supply
- ⑦ Maximum output current
- ⑧ Serial number
- ⑨ 2D matrix code, contains the order numbers of the sender/receiver, the order number of the MLG-2, and the serial number
- ⑩ Diagram of the M12/5-pin male connector
- ⑪ Pin assignment of the M12/5-pin male connector
- ⑫ Pictogram diagram

3.2 Type code of the MLG-2 Prime

Example

MLG-2 with 5 mm beam separation, type Prime, detection height 145 mm, 3 switching outputs, no options, 5 m sensing range, as well as preconfiguration for object detection and height classification

1	2	3	4	5	6	7	8	9	10	11	12	13	14	15	16	17
M	L	G	0	5	S	-	0	1	4	5	D	1	0	5	1	3

Table 2: Example of an MLG-2 Prime type code

Position	Meaning	
1 ... 3	Product family	MLG
4 and 5	Beam separation	05 = 5 mm 10 = 10 mm 20 = 20 mm 25 = 25 mm 30 = 30 mm 50 = 50 mm

Table 3: Meaning of the positions in the type code

Position	Meaning	
6	Type	0 = Special type S = Prime
7	Hyphen	-
8 ... 11	Detection height	0000 = Special detection height see table 4, page 11
12	Interfaces, I/O	see table 5, page 11
13	Options	1 = none
14 and 15	Optical properties	see table 6, page 12
16 and 17	Preconfiguration of the I/O connections and the software	see "MLG-2 Prime preconfigurations", page 12

Table 3: Meaning of the positions in the type code

3.2.1 MLG-2 Prime monitoring height

	Type					
	MLG05...	MLG10...	MLG20...	MLG25...	MLG30...	MLG50...
Monitoring height [mm]	145	140	140	-	-	-
	295	290	280	275	270	250
	445	440	440	425	420	400
	595	590	580	575	570	550
	745	740	740	725	720	700
	895	890	880	875	870	850
	1045	1040	1040	1025	1020	1000
	1195	1190	1180	1175	1170	1150
	1345	1340	1340	1325	1320	1300
	1495	1490	1480	1475	1470	1450
	1645	1640	1640	1625	1620	1600
	1795	1790	1780	1775	1770	1750
	1945	1940	1940	1925	1920	1900
	2095	2090	2080	2075	2070	2050
	2245	2240	2240	2225	2220	2200
	2395	2390	2380	2375	2370	2350
2545	2540	2540	2525	2520	2500	
-	2690	2680	2675	2670	2650	
-	2840	2840	2825	2820	2800	
-	2990	2980	2975	2970	2950	
-	3140	3140	3125	3120	3100	

Table 4: MLG-2 Prime (mm) monitoring height

3.2.2 Combinations of MLG-2 Prime inputs and outputs

Position 12	Inputs and outputs, data interface	Connection type
A	1 × switching output (Q) and 2 × analog output (QA)	M12/5-pin, A-coded

Table 5: Possible combinations of MLG-2 Prime inputs and outputs

Position 12	Inputs and outputs, data interface	Connection type
D	3 × switching output (Q) or 1 × input (IN) and 2 × switching output (Q)	M12/5-pin, A-coded

Table 5: Possible combinations of MLG-2 Prime inputs and outputs

3.2.3 MLG-2 Prime sensing range and minimum detectable object length

Position 14 and 15	Sensing range	Minimum detectable object length
00	Special	Special
05	5 m	5 mm
08	8.5 m	5 mm

Table 6: MLG-2 Prime sensing range and minimum detectable object length

3.2.4 MLG-2 Prime preconfigurations

Position 16, 17	Qa1	Qa2	Q1/C	Inverted	Teach
01	FBB	LBB	Object detection	-	Standard teach-in
02	FBB	LBB	Object detection	-	Cross beam
03	FBB	LBB	Contamination warning	-	Standard teach-in
04	FBB	LBB	Object detection	Q1 inverted	Standard teach-in
13	NBB	FBB	Object detection	Q1 inverted	Standard teach-in
14	NBB	LBB	Object detection	Q1 inverted	Standard teach-in
17	NBB	FBB	Object detection	Q1 inverted	Cross beam
19	NBB	FBB	Object detection	-	Automatic teach-in
26	NBB	LBB	Object detection	Q1 inverted	Automatic teach-in

Table 7: Preconfiguration of MLG-2 Prime with I/O combination A (see table 5, page 11)

Position 16, 17	Q1/C	Q2/IN1	Q3	Inverted	Teach
01	Automatic height classification	Automatic height classification	Automatic height classification	-	Standard teach-in
02	Automatic object recognition	Automatic object recognition	Automatic object recognition	-	Standard teach-in
03	Object detection	Contamination warning	Automatic height classification	-	Standard teach-in
04	Object detection	Contamination warning	Automatic height classification	-	Cross beam
13	Object detection	Automatic height classification	Automatic height classification	Q1 inverted	Standard teach-in

Table 8: Preconfiguration of MLG-2 Prime with I/O combination D (see table 5, page 11)

Position 16, 17	Q1/C	Q2/IN1	Q3	Inverted	Teach
17	Object detection	Automatic height classification	Automatic height classification	Q1 inverted	Cross beam
19	Object detection	Automatic height classification	Automatic height classification	-	Automatic teach-in
25	Object detection	Automatic height classification	Automatic height classification	Q1 inverted	Automatic teach-in
31	Object detection	Teach-in	Automatic height classification	Q1 inverted	Standard teach-in
32	Contamination warning	Object detection	Automatic height classification	Q2 inverted	Cross beam

Table 8: Preconfiguration of MLG-2 Prime with I/O combination D (see table 5, page 11)

3.3 MLG-2 Prime product properties

- Different beam separations
- Monitoring heights from 140 to 3,140 mm
- Operating range up to 5 m or 8.5 m
- Quick response time
- Configuration via control panel
- Integrated applications including object detection, height classification, etc.

3.4 Setup and function

The MLG-2 is an optical light grid. It comprises a sender and a receiver.

The sender consists of sender optics, several sender elements (LEDs), and actuation electronics. The receiver consists of receiver optics, several receiver elements (photodiodes) and evaluation electronics.

3.4.1 MLG-2 Prime device components



Figure 3: MLG-2 Prime

- ▣ Receiver
- ▣ Sender
- ① Receiver connection
- ② Sender connection

The receiver has a connection for the power supply as well as for inputs and outputs. The sender has a connection for the power supply as well as for a test input.

3.4.2 Measurement principle

Provided no object is located between the sender and receiver elements, the light beams from the sender elements will hit the receiver elements.

If an object is located between the sender and receiver elements, the light beams will be blocked, depending on the size of the object.

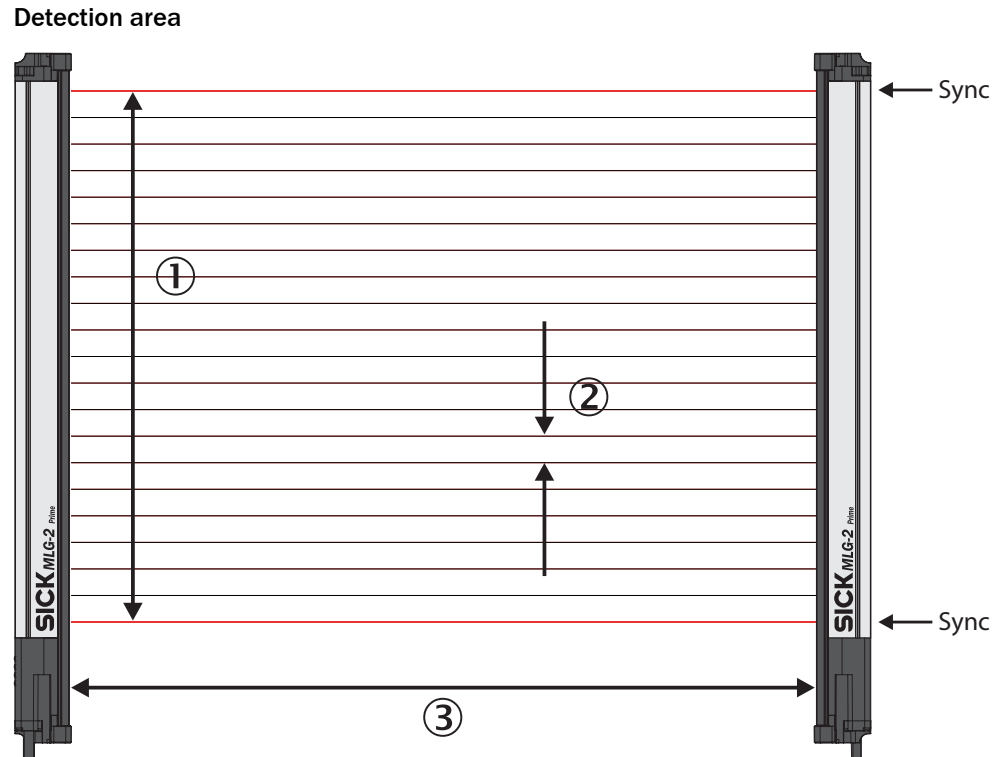

Figure 4: Detection area of the MLG-2

- ① Monitoring height
- ② Beam separation
- ③ Sensing range

The detection area is determined by the monitoring height and the sensing range of the light grid. The monitoring height is determined by the beam separation and the number of beams. The sensing range of the light grid is the distance between sender and receiver.

3.4.3 MLG-2 Prime synchronization

The sender and receiver synchronize with each other optically, so **no** electrical connection is necessary. For this reason, either the first or last beam of the MLG-2 Prime must always be made. If both beams are blocked, no measurements can be taken. As soon as one of the beams is made again, the sender and receiver synchronize once more. However, this can take up to seven scan cycles (see "Scan time", page 18).

3.4.4 Detection height

Beam separations

In order to achieve different levels of measurement accuracy, the MLG-2 is available with different beam separations.

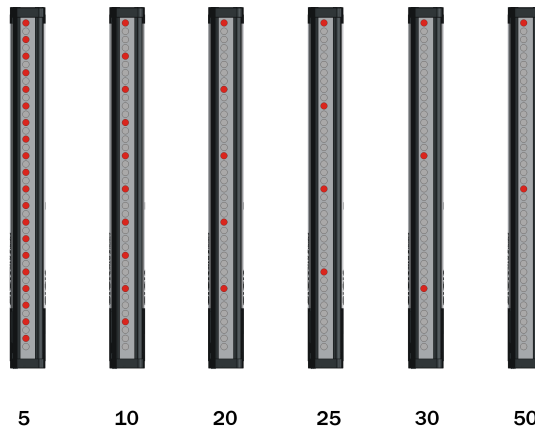

Figure 5: Schematic representation of available beam separations (mm)

Maximum and minimum detection height

The number of LEDs is limited to 510. This results in different maximum detection heights depending on the beam separation. The minimum detection height is determined by the beam separation and the smallest module size for this beam separation.

Beam separation	Maximum detection height	Minimum detection height
5 mm	2,545 mm	145 mm
10 mm	3,140 mm	140 mm
20 mm	3,130 mm	130 mm
25 mm	3,125 mm	275 mm
30 mm	3,120 mm	270 mm
50 mm	3,100 mm	250 mm

Table 9: Maximum detection heights

3.4.5 Teach-in

During the teach-in process, the switching thresholds for all beams are individually adjusted for the sensing range and the ambient conditions.

After teach-in has been completed, it must be ensured that the setup is no longer changed otherwise another teach-in will have to be carried out.

3.4.5.1 Teach-in of the MLG-2 Prime

The MLG-2 Prime provides the following options for carrying out a teach-in:

- Pressing the teach-in button
- Signal at a digital input
- IO-Link

3.4.6 Beam blanking

Individual beams can be blanked.

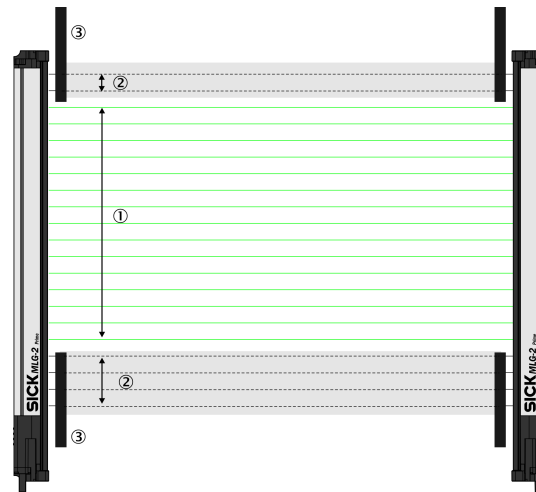

Figure 6: Detection area with beams blanked

- ① Included beams
- ② Blanked beams
- ③ Structural restrictions on the detection area



NOTE

One of the two sync beams must be made, both beams may not be blanked at the same time (see "Measurement principle", page 14).

3.4.6.1 Beam blanking for the MLG-2-Prime

The device can also be set so that beams are blanked during the teach-in.

The beam blanking function blanks the beams that are currently blocked for every teach-in process (see "System settings on operating level 2", page 46).



NOTE

If an object is located in the detection area during the teach-in process, this will not be identified as an error.

3.4.7 Sensing ranges

Operating range

Light grids are generally available with a 5 m or 8.5 m sensing range. This is referred to as the operating range, which includes an operating reserve.

Limiting range

It is also possible to operate the MLG-2 up to its limiting range, which goes beyond the operating range.

Minimum range

The minimum range is the minimum distance between the sender and the receiver.

Operating range	Limiting range	Minimum range
5 m	7 m	0.2 m
8.5 m	12 m	0.5 m

Table 10: Limiting range

Operation within the limiting range requires the following conditions:

- Clean ambient conditions
- Front screens are cleaned regularly
- Regular teach-in

3.5 Scan time

In the MLG-2, not all light beams are active at the same time, instead one light beam is activated after the other starting from the bottom.

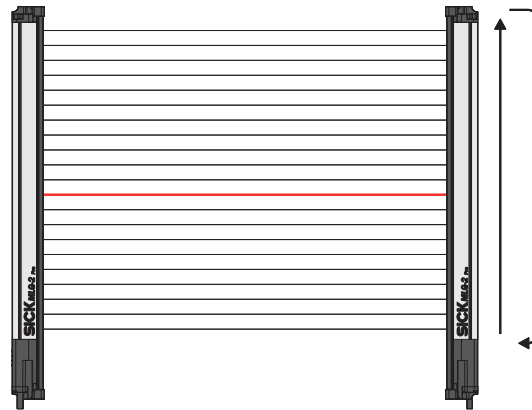

Figure 7: Standard scan method

The scan time increases according to the number of beams of an MLG-2.

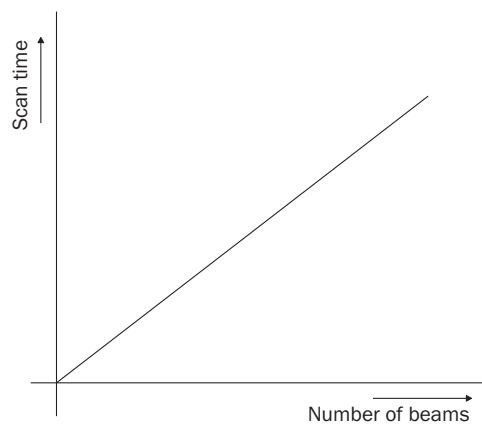

Figure 8: Scan time in relation to the number of beams

The scan time is used to determine the **response times** of the outputs, the **minimum presence time** of an object and the **repeat accuracy of a measurement result (reproducibility)**.

- The **response time** is the time it takes for an output to react following the detection of an object/gap. The maximum response time is $3 \times$ the scan time plus the transmission time to the outputs.
- The **minimum presence time** is the time an object or a gap has to be in the detection area for it to be detected. The minimum presence time is $\max. 2 \times$ the scan time.
- The repeat accuracy of a measurement result (**reproducibility**) is the amount of time by which an object detection can differ from a previous or subsequent detection. The reproducibility time is $1 \times$ the scan time.

3.5.1 MLG-2 Prime response time and minimum presence time

For the MLG-2 Prime, you can read out the response time and minimum presence time in the diagram [see figure 45, page 54](#).

3.5.2 Scan time with cross-beam function

When the cross-beam function is enabled, the light beam from a sender LED is received by three receiver diodes in two scans. This doubles the scan time.

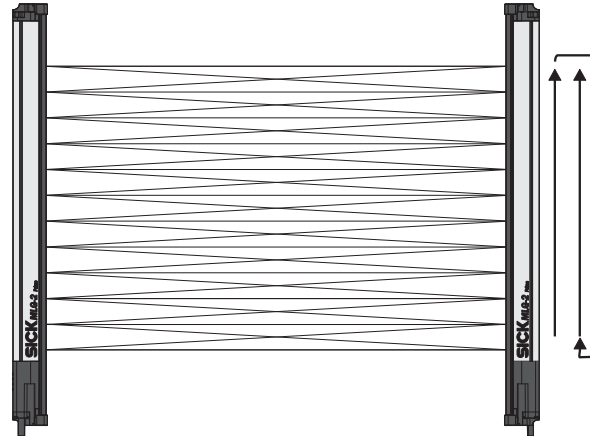

Figure 9: Cross-beam function

3.6 Beam separation and minimum detectable object

The measurement accuracy achieved by the MLG-2 depends on the beam separation.

3.6.1 Minimum detectable object with parallel-beam function

In order for an object to be detected continuously, it must completely cover at least one beam. This is referred to as the minimum detectable object, or MDO.

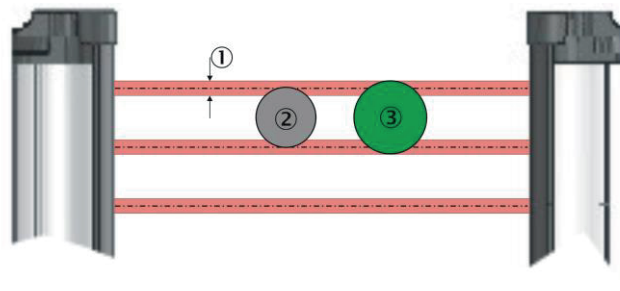

Figure 10: Minimum detectable object

- ① Beam diameter
- ② Object is not completely reliably detected
- ③ Object is reliably detected (meets requirements of minimum detectable object size)



NOTE

For moving objects, the minimum detectable object depends on the speed of the object.

Beam separation	Minimum detectable object (stationary object) ¹
5 mm	9 mm
10 mm	14 mm
20 mm	24 mm
25 mm	29 mm
30 mm	34 mm
50 mm	54 mm

Table 11: Minimum detectable object depends on the MLG-2 Prime beam separation

¹ Only if the object also meets the minimum detectable object length requirements.

3.6.2 Minimum detectable object length

When an object moves through the detection area, it must have a certain length.

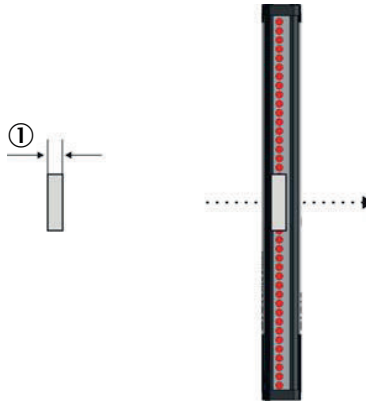

Figure 11: Minimum detectable object length

① Minimum detectable object



NOTE

For moving objects, the minimum detectable object length also depends on the speed of the object.

Beam separation	Minimum detectable object length (stationary object) ¹
5 ... 50 mm	5 mm

Table 12: Minimum detectable object length for the MLG-2 Prime

¹ Only if the object also meets the minimum detectable object requirements.

3.6.3 Minimum detectable object with cross-beam function

The parallel-beam function is used for measuring by default. With the parallel-beam function, each light beam is received only by the receiver element situated directly opposite.

With the cross-beam function, a sender LED projects beams to several receiver diodes. The cross-beam function increases the measurement accuracy and enables the detection of smaller objects.

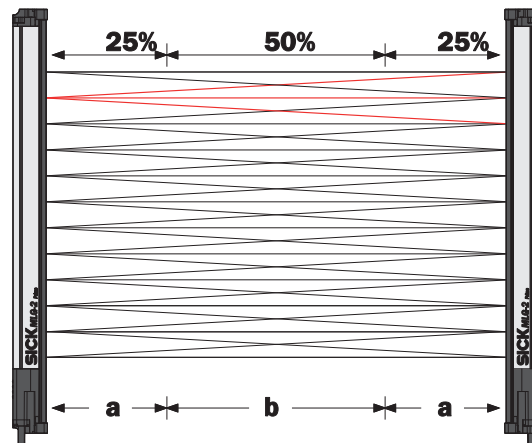

Figure 12: Cross-beam function

A minimum distance between the sender and the receiver is required for the cross-beam function. The minimum detectable object size depends on the position of the object within the detection area. Detection of the smaller minimum detectable object size is therefore only possible in the central area (b) of the detection area.

- The cross-beam function is only useful for object detection ($NBB \leq 1$). For other applications (height classification, object recognition, etc.), the results of the parallel-beam function are used.
- Use of the cross-beam function increases the response time.
- With the cross-beam function, a minimum distance needs to be maintained between sender and receiver. The minimum distance depends on the aperture angle of the light grid.
- For moving objects for the cross-beam function, the minimum detectable object depends on the speed of the object.

Beam separation	Minimum distance 5-m variant	Minimum distance 8.5-m variant	Minimum detectable object (stationary object)	
			In area B	In area A
5 mm	110 mm	120 mm	6.5 mm	9 mm
10 mm	220 mm	240 mm	9 mm	14 mm
20 mm	440 mm	480 mm	14 mm	24 mm
25 mm	550 mm	600 mm	16.5 mm	29 mm
30 mm	660 mm	720 mm	19 mm	34 mm
50 mm	1,110 mm	1200 mm	29 mm	54 mm

Table 13: Minimum detectable object during MLG-2 Prime cross-beam function

3.7 Operating reserve

The operating reserve defines the operational safety before contamination, vibrations, misalignment, temperature fluctuations, etc. cause the MLG-2 to produce incorrect measurements.

The MLG-2 is subject to a certain level of contamination depending on its environment and application. In principle, the MLG-2 must be cleaned regularly and a teach-in should be carried out after cleaning.

3.8 Interfaces

The MLG-2 can be used to evaluate the measurements in different ways. The MLG-2 provides various interfaces for data output.

- Switching outputs (Push-Pull)
- Analog outputs
- IO-Link interface

The MLG-2 can also preprocess the beam blocks (beam function, e.g., NBB – number of beams blocked) and output the data via bus or analog interfaces.

The preprocessed data can be assigned directly to the switching outputs via predefined applications.

3.8.1 Preliminary evaluation

Beam functions for preliminary evaluation

The MLG-2 creates a preliminary evaluation on the basis of the beam status, e.g.:

- NBB – Number of Beams Blocked
- LBB – Last Beam Blocked
- FBB – First Beam Blocked

The results of the preliminary evaluation can be output via the data interfaces and processed further externally. Alternatively, they can first be processed in a function programming option in the MLG-2.

3.8.2 Configurable applications of the MLG-2 Prime

The MLG-2 provides predefined applications which are assigned to the outputs. The following options are available for configuring the applications:

- Via the control panel (see ["Configuration with the control panel"](#), page 38)
- Using IO-Link (see ["IO-Link"](#), page 48)

Application	MLG-2 Prime
Height classification	LBB/FBB
Object detection/object width	NBB
Contamination warning	■
Object recognition	NBB

Table 14: Configurable applications for switching outputs

3.9 Display and operating elements

3.9.1 Sender

The sender has three LEDs on its front. The LEDs are located on the connection side.

The section [LED indicators and error indicators](#) on [page 50](#) explains the meaning of the LED indicators.

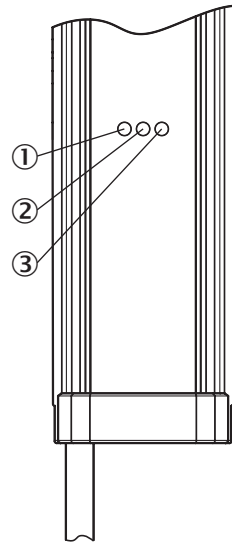

Figure 13: LEDs on the sender

- ① Yellow
- ② Red
- ③ Green

3.9.2 Receiver

The receiver has three LEDs on its front and a control panel with LEDs and membrane keys on its rear. The LEDs and the control panel are located on the connection side.

The section [LED indicators and error indicators](#) on [page 50](#) explains the meaning of the LED indicators.

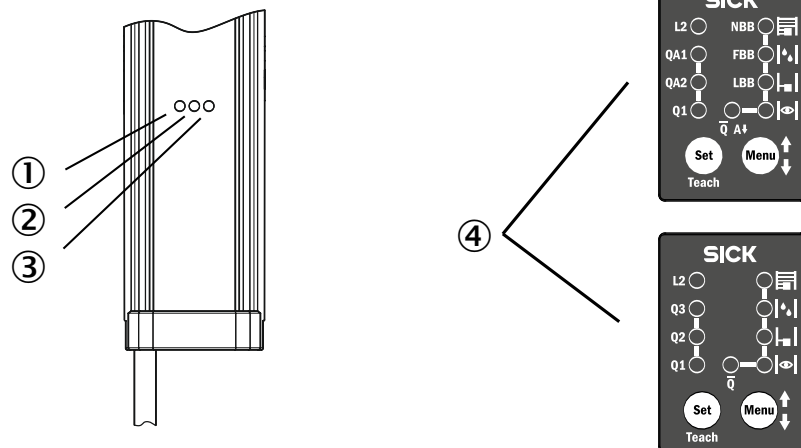

Figure 14: LEDs on the front of the receiver

- ① Yellow
- ② Red

- ③ Green
- ④ LEDs on the control panel

Control panels

The MLG-2 Prime and its outputs can be configured for specific applications using the membrane keys on the control panel. Depending on the device type, a range of functions can be set in this manner (see "Configuration with the control panel", page 38).

In addition, the teach-in process for the MLG-2 can be started by pressing the **Teach** pushbutton.

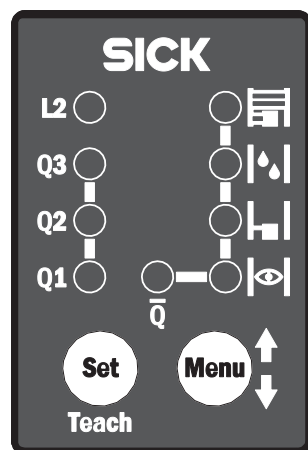

Figure 15: MLG-2 Prime control panel with switching outputs

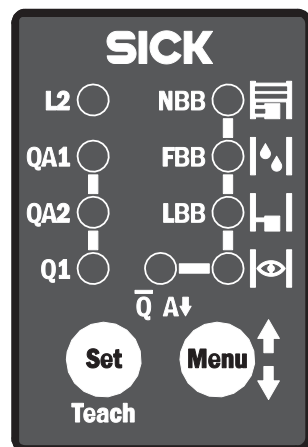

Figure 16: MLG-2 Prime control panel with analog outputs and switching output

The MLG-2 control panel can be locked to prevent incorrect operation. The lock can be activated and deactivated using IO-Link or the pushbuttons on the control panel.

Locking the control panel

- ▶ Press the **Teach (Set)** pushbutton for 15 s.
- ✓ The control panel is locked; the configuration cannot be changed.
- ✓ If a pushbutton is pressed on the control panel, the LED L2 lights up briefly.

Disabling the lock

- ▶ On the MLG-2 Prime, press the **Menu** and **Set** pushbuttons simultaneously for 15 s.
- ✓ The lock is disabled again.

3.10 Inputs

3.10.1 Switching input on the MLG-2 Prime receiver

On the MLG-2 Prime, no switching input is provided for the teach-in process as standard. A preconfigured variant is possible (see "MLG-2 Prime preconfigurations", page 12).

3.10.2 Test input on the sender

The test input can be used to switch off the sender. This simulates a complete blocking of the beams. This makes it possible to test the behavior of the switching or analog outputs that have been configured accordingly.

3.11 Application examples

3.11.1 Application examples for the MLG2 Prime

Typical applications for the MLG-2 Prime include height classification, start and end detection, loop control, access controls or width measurement.

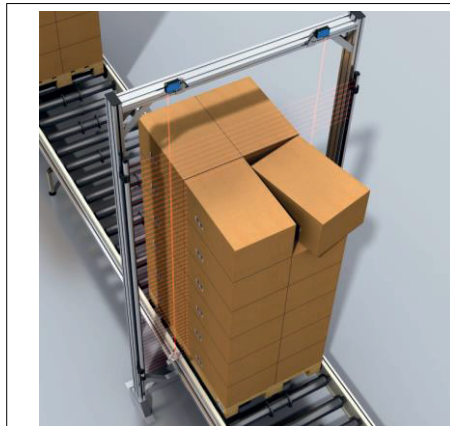

Figure 17: Height classification and overhang measurement

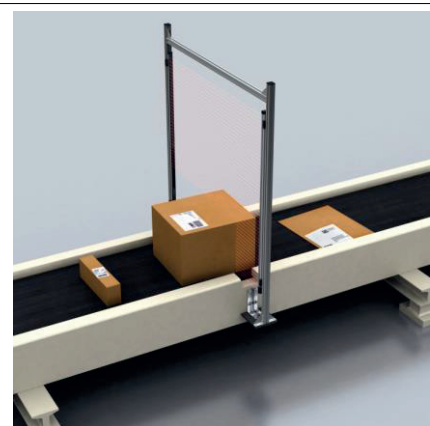

Figure 18: Position detection on a conveyor belt

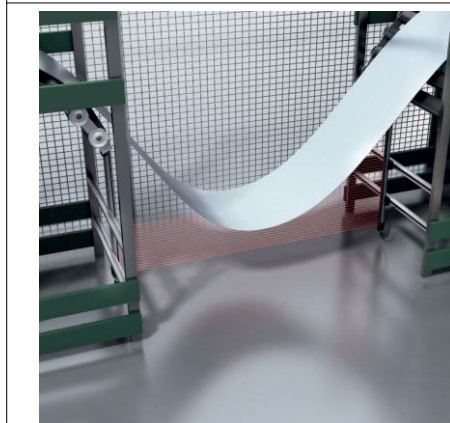

Figure 19: Slack regulation

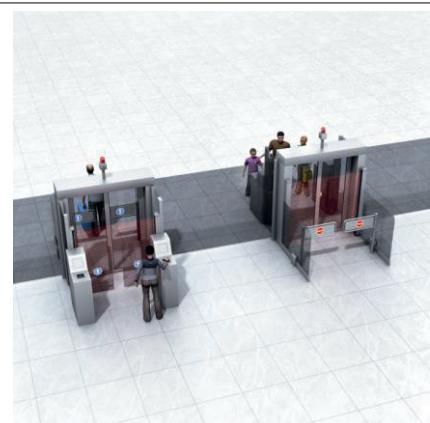

Figure 20: Access control

Table 15: Application examples for the MLG-2 Prime

4 Mounting

4.1 Scope of delivery

- 1 × sender
- 1 × receiver
- 4/4 × QuickFix brackets¹⁾
- 1 × Quick Start Guide

4.2 Recommended mounting arrangements

When several MLG-2s are mounted close to one another, there is a risk of mutual interference. This is particularly likely if there are shiny surfaces nearby or if the objects being detected are shiny.

Therefore, when mounting two MLG-2s close to one another, their light beams should be oriented in opposite directions.

4.2.1 Mounting with light in opposite directions

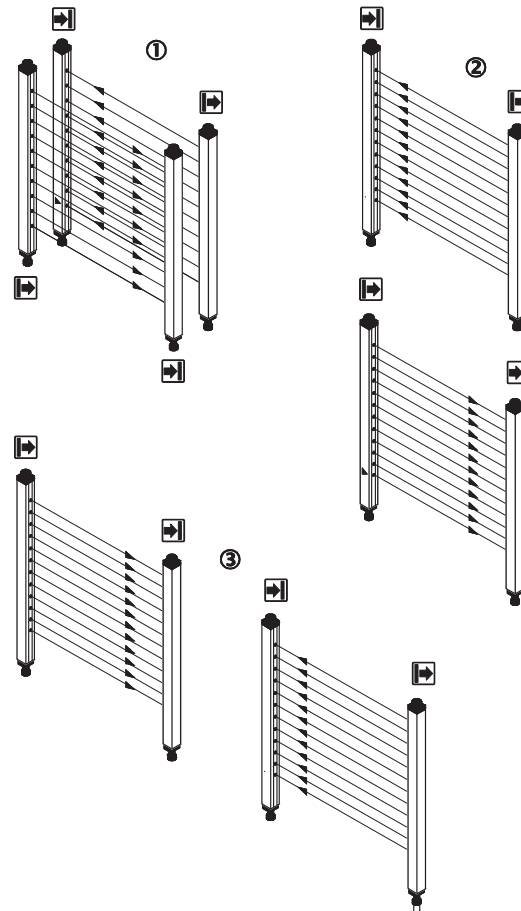

Figure 21: Placement with light in opposite directions

- ① Two MLG-2s, one behind the other
- ② Two MLG-2s, one above the other
- ③ Two MLG-2s, one next to the other

¹⁾ 6 x QuickFix brackets for detection heights above 2 m.

**NOTE**

When two MLG-2s are placed opposite one another and their light beams are in opposite directions, ① reflections may occur from sender 1 to receiver 2 in the case of shiny objects.

4.2.2 Mounting with light in the same direction

When several MLG-2s are mounted with their light beams oriented in the same direction, a minimum distance must be maintained between the MLG-2s. The minimum distance increases as the distance between the sender and receiver increases and is dependent on the operating range.

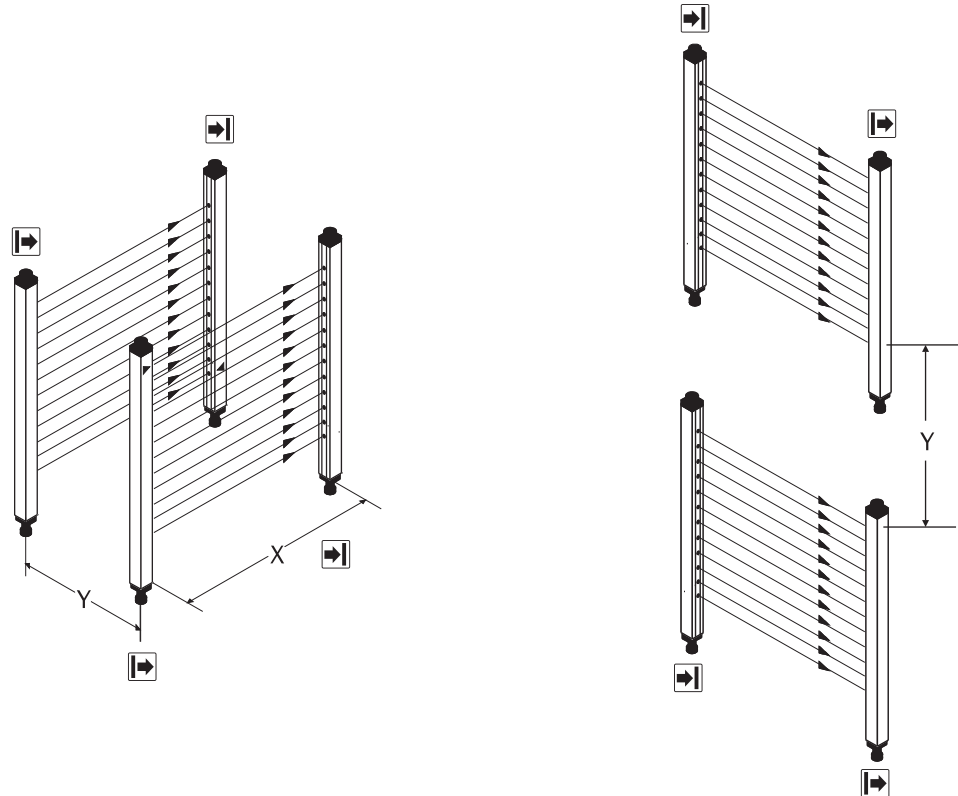

Figure 22: Distances when light is in the same direction

- X Operating range
- Y Minimum distance of the MLG-2

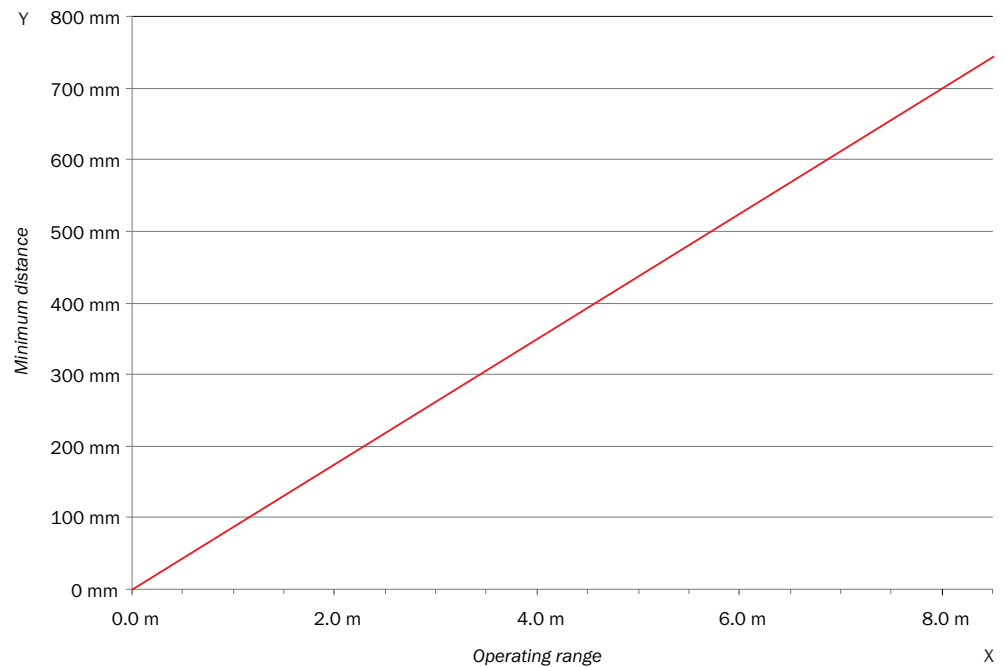

Figure 23: Graph, distances when light is in the same direction

4.2.3 Minimum distance from reflective surfaces

Reflective surfaces between the sender and receiver may result in disruptive reflections and beams being deflected and, hence, result in a failure to detect objects.

In the case of reflective surfaces, a minimum distance must be maintained between the reflective surface and the light beams to ensure reliable operation.

This minimum distance depends on the distance between sender and receiver and on the operating range.

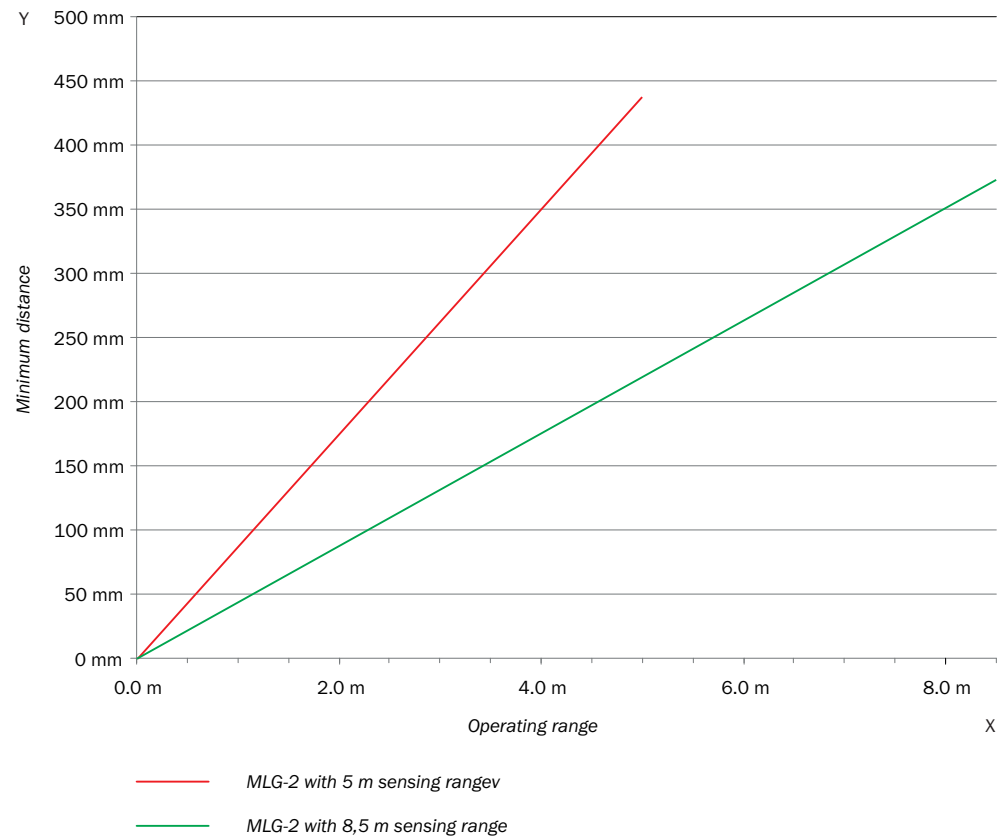

Figure 24: Graph, minimum distance from reflective surfaces

This distance also applies to reflective surfaces located next to the light grid (parallel to the sending/receiving axis).

4.3 Mounting procedure

- ▶ Mount the sender and receiver at the same height. For minor adjustments when aligning, the sender and receiver can be adjusted in the brackets.
- ▶ If possible, mount the top bracket at a height such that the offset in the housing of the MLG-2 sits on the bracket. This prevents the MLG-2 from sliding down.

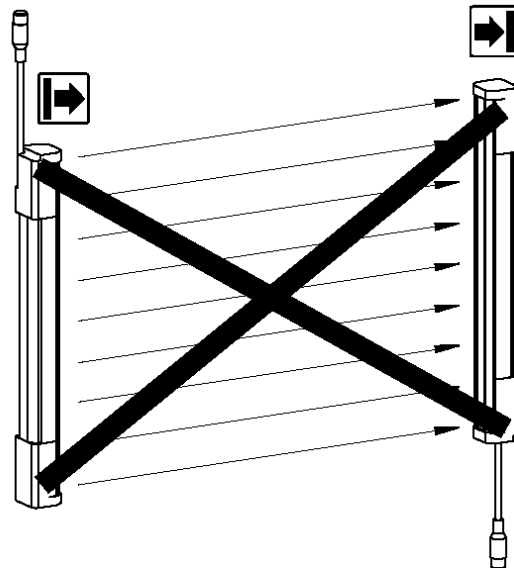

Figure 25: The sender and receiver are aligned incorrectly

The end with the cable connection must point in the same direction for both devices. Sender and receiver must **not be installed at 180° rotated relative to each other.**

Tighten the screws used to mount the bracket to a torque of 5 to 6 Nm. Tighten the screws used to secure the MLG-2 in the bracket to a torque of 2.5 to 3 Nm. Higher torques can damage the bracket while lower torques do not provide adequate fixation to prevent the MLG-2 from moving in the event of vibrations.

When mounting, make sure that sender and receiver are aligned correctly. The optical lens systems of sender and receiver must be located opposite one another. If necessary, use a water level to check the components are parallel.

4.3.1 Mounting the QuickFix bracket

QuickFix brackets can be mounted in two ways:

- On the side
- On the back

The two mounting surfaces for the brackets of the sender or receiver must not be angled more than $\pm 2^\circ$ to each other. If this is not possible, use the optional FlexFix bracket.

Mounting the QuickFix bracket on the side of a machine or profile frame

Up to a monitoring height of 2 m, the sender and receiver are mounted with two QuickFix brackets each.

For a monitoring height of more than 2 m, the sender and receiver are mounted with three QuickFix brackets each.

The QuickFix bracket consists of two parts, which are pushed into each other. An M5 screw is used to join both parts and to clamp the housing (sender or receiver).

Mounting can be carried out in two ways:

- With the M5 screw through the QuickFix bracket to the machine or profile frame. A screw nut or threaded hole is required on the machine or profile frame.
- With the M5 screw through the machine or profile frame to the QuickFix bracket. A screw nut is required for each QuickFix bracket.

When choosing the length of the M5 screw (hexagon head or cylinder head screw), consider the QuickFix bracket and the machine or profile frame.

**CAUTION****Risk of injury from protruding screw thread!**

When mounting through the machine or profile frame to the QuickFix bracket, the M5 screw can present an injury risk if too long.

- ▶ Select an appropriate screw length to prevent any risk of injury from an overrun.

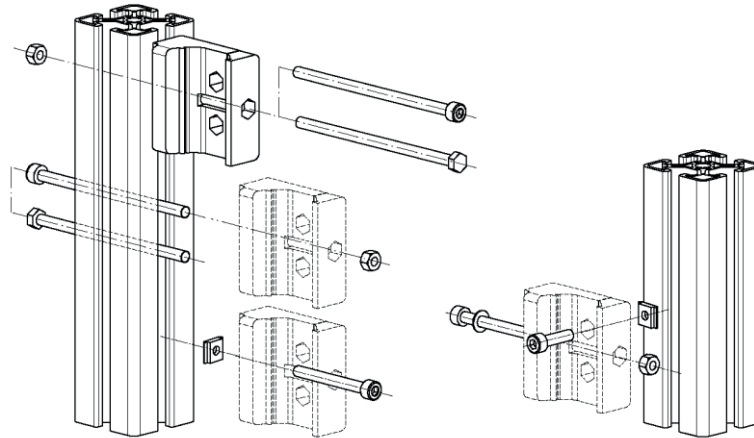

Figure 26: Mount QuickFix bracket to a profile frame

Mount QuickFix bracket to the back of a device column**NOTE**

The QuickFix bracket has cable routing. Depending on the installation, the cable routing can make mounting easier.

The sender and receiver are each mounted with two QuickFix brackets.

The QuickFix bracket consists of two parts, which are pushed into each other. An M5 screw is used to join both parts and to clamp the housing (sender or receiver).

You need two M5 screws per bracket if mounting them on the back.

- ▶ Choose the length of the M5 screw such that it is possible to clamp the housing (sender or receiver) in the QuickFix bracket.

4.3.2 Mounting the FlexFix bracket

In the FlexFix bracket, sender and receiver can be flexibly rotated by $\pm 15^\circ$.

FlexFix brackets can be mounted in two ways:

- On the side
- On the back

Mounting the FlexFix bracket on a profile frame

The sender and receiver are mounted at the designated points using two FlexFix brackets in each case.

M5 screws are inserted through the FlexFix bracket and into the machine or profile frame for mounting. A screw nut or threaded hole is required on the machine or profile frame.

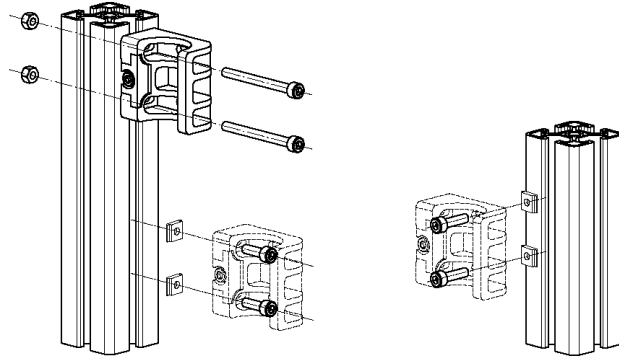

Figure 27: Mounting the FlexFix bracket on a profile frame

Screwing the sender or receiver into the FlexFix brackets

After mounting the FlexFix brackets, screw the sender or receiver into the FlexFix brackets from the front. Then align the sender and receiver.



NOTE

The MLG-2 can only be screwed in when both FlexFix brackets are in alignment. If necessary, use a water level to check the components are parallel.

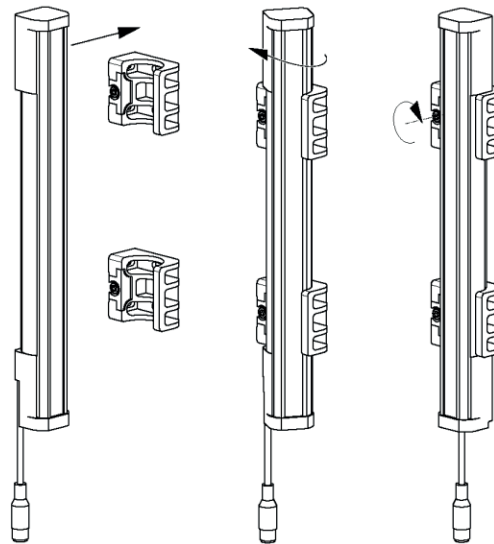

Figure 28: Inserting the MLG-2 in the FlexFix brackets

- ▶ Use an M5 screw to fix the position of the sender and receiver in the FlexFix bracket.

5 Electrical installation



CAUTION

De-energize the system!

The system could inadvertently start while you are connecting the devices.

- Make sure that the entire system is disconnected from the power supply during the electrical installation work.



NOTE

- The MLG-2 complies with the EMC regulations for the industrial sector (Radio Safety Class A). It may cause radio interference if used in a residential area.
- Do not lay cables parallel to other cables, especially not to devices with a high level of radiated emission, such as a frequency converter.



NOTICE

This device must be protected with a 1 A 30 V DC fuse.

Wire cross-section		Maximum amperage for over-current protection
AWG	mm ²	
20	0.52	5
22	0.32	3
24	0.20	2
26	0.13	1
28	0.08	0.8
30	0.05	0.5

Table 16: Overcurrent protection

5.1 Connections of the MLG-2 Prime

For the MLG-2 Prime, the sender and receiver synchronize with each other optically. This means that **no cabling** is required between the sender and receiver.

Sender connection: M12/5-pin, A-coded

Male connector	Pin	Signal	Meaning	Color
	1	L+	24 V supply voltage	Brown
	2	Not connected	Not connected	White
	3	M	GND supply voltage	Blue
	4	Test_In	Test input	Black
	5	Not connected	Not connected	Gray

Table 17: Pin assignment, MLG-2 Prime sender

Receiver I/O connection with switching outputs (Q): M12/5-pin, Acoded

Male connector	Pin	Signal	Meaning	Color
	1	L+	24 V supply voltage	Brown
	2	Q2/IN1	Switching output 2 or Switching input 1 ¹	White
	3	M	GND supply voltage	Blue
	4	Q1/C	Switching output 1 with IO-Link interface	Black
	5	Q3	Switching output 3	Gray

Table 18: Pin assignment, I/O, MLG2 Prime receiver with Q

¹ Depending on the variants ordered see "MLG-2 Prime preconfigurations", page 12.

Receiver I/O connection with analog outputs (QA): M12/5-pin, Acoded

Male connector	Pin	Signal	Meaning	Color
	1	L+	24 V supply voltage	Brown
	2	QA1	Analog output 1	White
	3	M	GND supply voltage	Blue
	4	Q1/C	Switching output 1 with IO-Link interface	Black
	5	QA2	Analog output 2	Gray

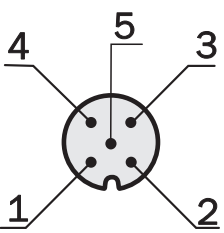
Table 19: Pin assignment, I/O, MLG2 Prime receiver with QA

6 Commissioning

6.1 Mechanical alignment of sender and receiver

After mounting and electrical installation, the sender and receiver must be aligned with each other. No objects should be located between the sender and the receiver. The light path must be clear.

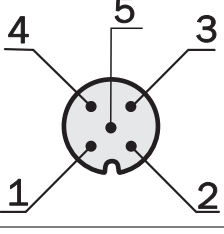
Alignment with the QuickFix bracket

You have the following adjustment options with the QuickFix bracket:

- Adjust vertically (H)

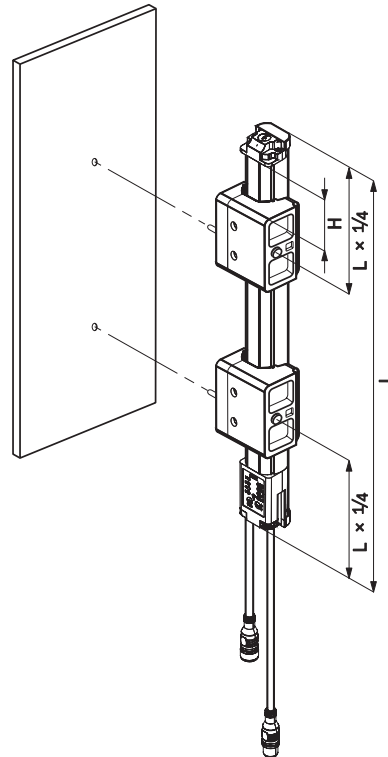

Figure 29: Alignment with the QuickFix bracket

Alignment with the FlexFix bracket

You have the following adjustment options with the FlexFix bracket:

- Adjust vertically (H)
- Rotate ($\pm 15^\circ$)

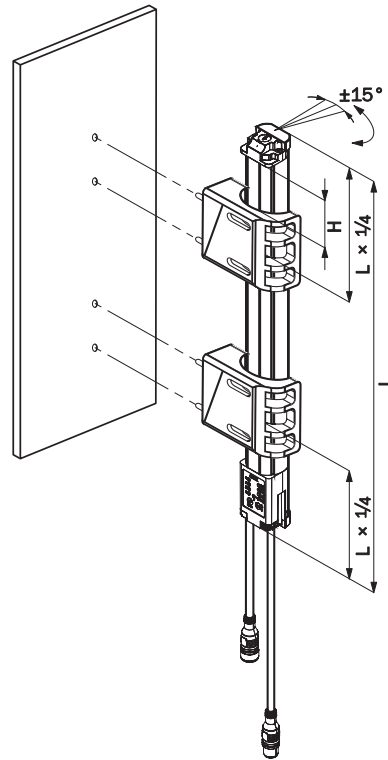

Figure 30: Alignment with the FlexFix bracket

6.2 Alignment and teach-in

To ensure the alignment aid works perfectly, the device should be rotated once from the left bracket stop to the right stop. This makes the best possible settings for the input sensitivity and ensures that the alignment aid shows the most helpful values.

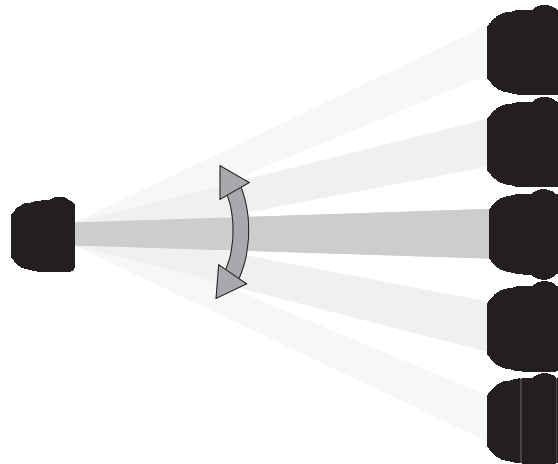

Figure 31: Rotate the receiver once

6.2.1 MLG-2 Prime

The alignment aid is activated at the factory and the outputs are deactivated. A valid measurement is not possible. The MLG-2 deactivates the alignment aid automatically after the teach-in process.

When the device is switched on, the four green LEDs on the right-hand side of the control panel show the alignment quality.

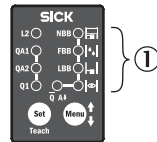

Figure 32: Alignment aid – LEDs alignment quality

① LEDs for alignment quality

- ▶ Align the MLG-2 such that as many LEDs illuminate as possible. It may be that they do not all light up; this is normal. Even if not all of the LEDs light up, the teach-in process adjusts each beam so that it is located in the optimum functional range.
- ▶ Now fix the position of the sender and receiver.

Teach-in

- ▶ Press the **Teach** pushbutton (< 1 s).²⁾
- ▶ All LEDs light up briefly one after another (sequential light). The sensitivity is stored.
- ✓ ☀ **1 Hz yellow**
- ✓ The yellow LED on the front flashes slowly.

If the teach-in process is successful, all LEDs on the control panel go out, as does the yellow LED on the front of the device. The MLG-2 is operational.

If the teach-in process was unsuccessful, all LEDs on the control panel flash quickly, as does the red LED on the front of the device.

- ▶ Then, check that the MLG-2 is correctly aligned, that the front screens are clean and that there are no objects located in the light path.
- ▶ Then carry out the teach-in process again.

2) On the MLG-2 Prime, the teach-in process can also be triggered via IO-Link or the Teach input.

7 Operating the MLG2 Prime

7.1 Configuration with the control panel

The MLG-2 has a control panel on the receiver which is used for teaching in, alignment, and configuration. The control panel is located on the connection side of the receiver.

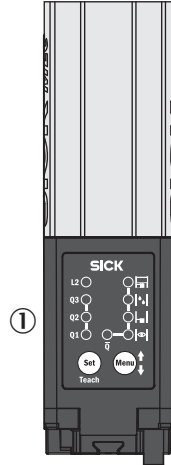

Figure 33: Control panel with LEDs and membrane keys

① Control panel with LEDs and membrane keys

Different control panels are available depending on the type of outputs.

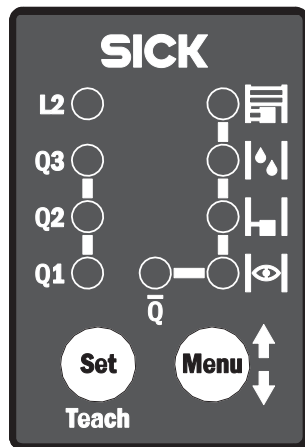

Figure 34: of the MLG-2 Prime with switching outputs

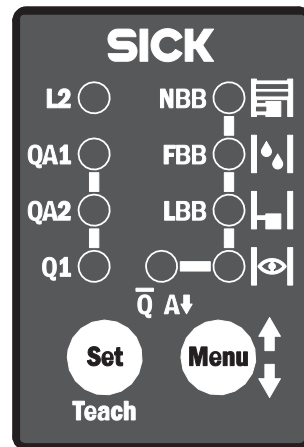

Figure 35: MLG-2 Prime control panel with analog outputs and switching output

7.1.1 Basic operation

The functions of the two control panels are essentially the same:

- The left-hand row of yellow LEDs represents the operating level and the outputs.
- The right-hand row of green LEDs represents the functions.
- You select the output settings on operating level 1 and the system settings on operating level 2.
- A flashing LED indicates that the output or function is preselected.

- A lit LED indicates that the output or function is set.
- ▶ Start configuration by pressing the **Menu** pushbutton.
Or:
- ▶ Switch to operating level 2 by pressing the **Menu** and **Set** pushbuttons simultaneously for more than 1 s.

**NOTE**

If you do not press either of the pushbuttons for 15 seconds, the MLG-2 automatically leaves the menu.

Symbol	Meaning
L2	Control panel level 2 active
Q1...Q3	Switching output (device-specific)
QA1/QA2	Analog output (device-specific)
Level 1 (output settings)	
For switching outputs	
	Object detection
	Contamination warning
	Height classification
	Object recognition
$\bar{Q} A \downarrow$	Output inverted/20...4 mA
For analog outputs	
NBB	Number of beams blocked
FBB	First beam blocked
LBB	Last beam blocked
Level 2 (system settings)	
	Reset to the factory setting
	Beam blanking for teach-in
	Activate/deactivate alignment aid
	Activate/deactivate cross-beam function

Table 20: Meaning of the displays



NOTE

With the **height classification** and **object recognition** applications, the reference objects must be located in the detection area.

7.1.3 Setting the application for analog outputs and switching output

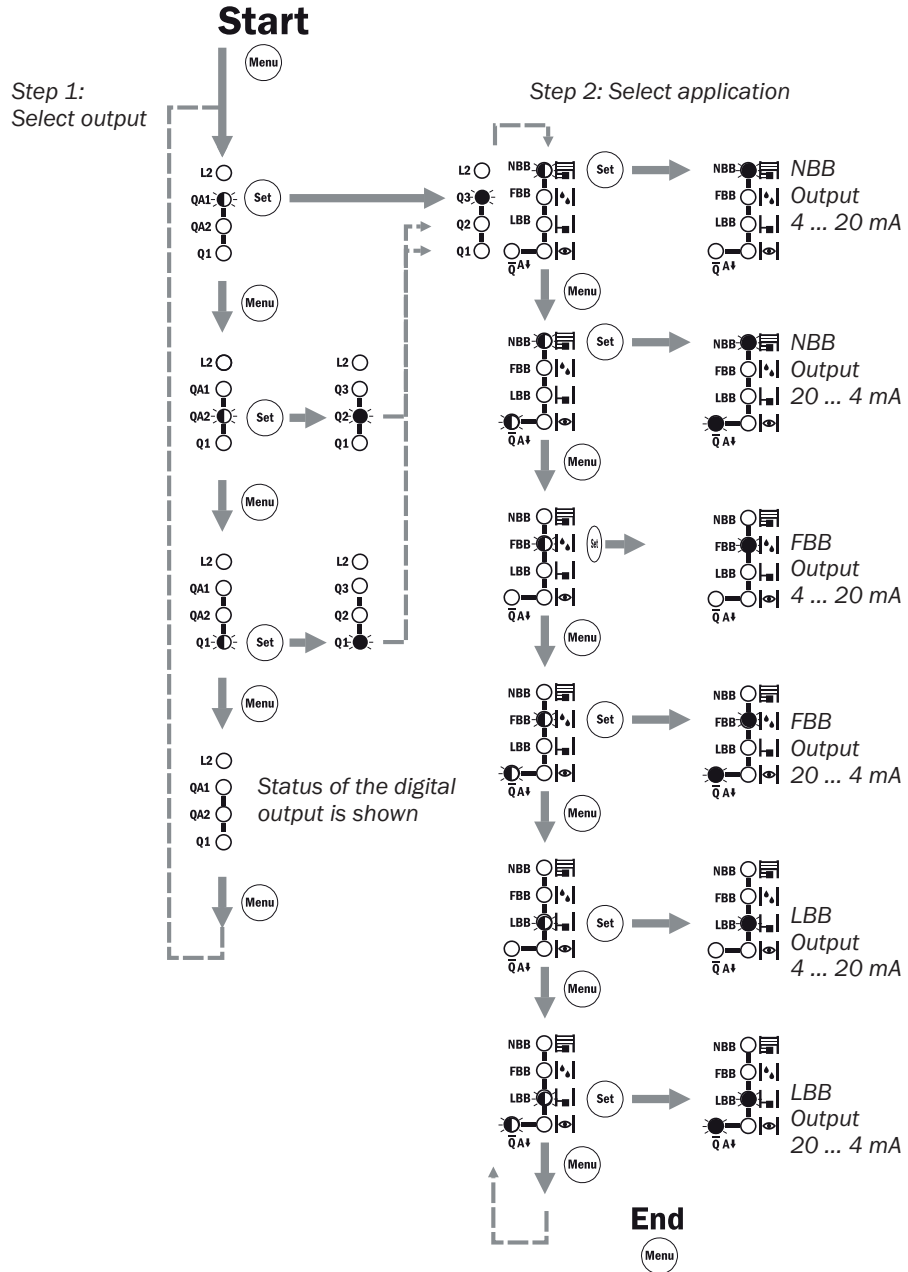

Figure 37: Graph, setting the output and application for MLG-2 Prime with analog outputs and switching output

7.1.4 System settings on operating level 2

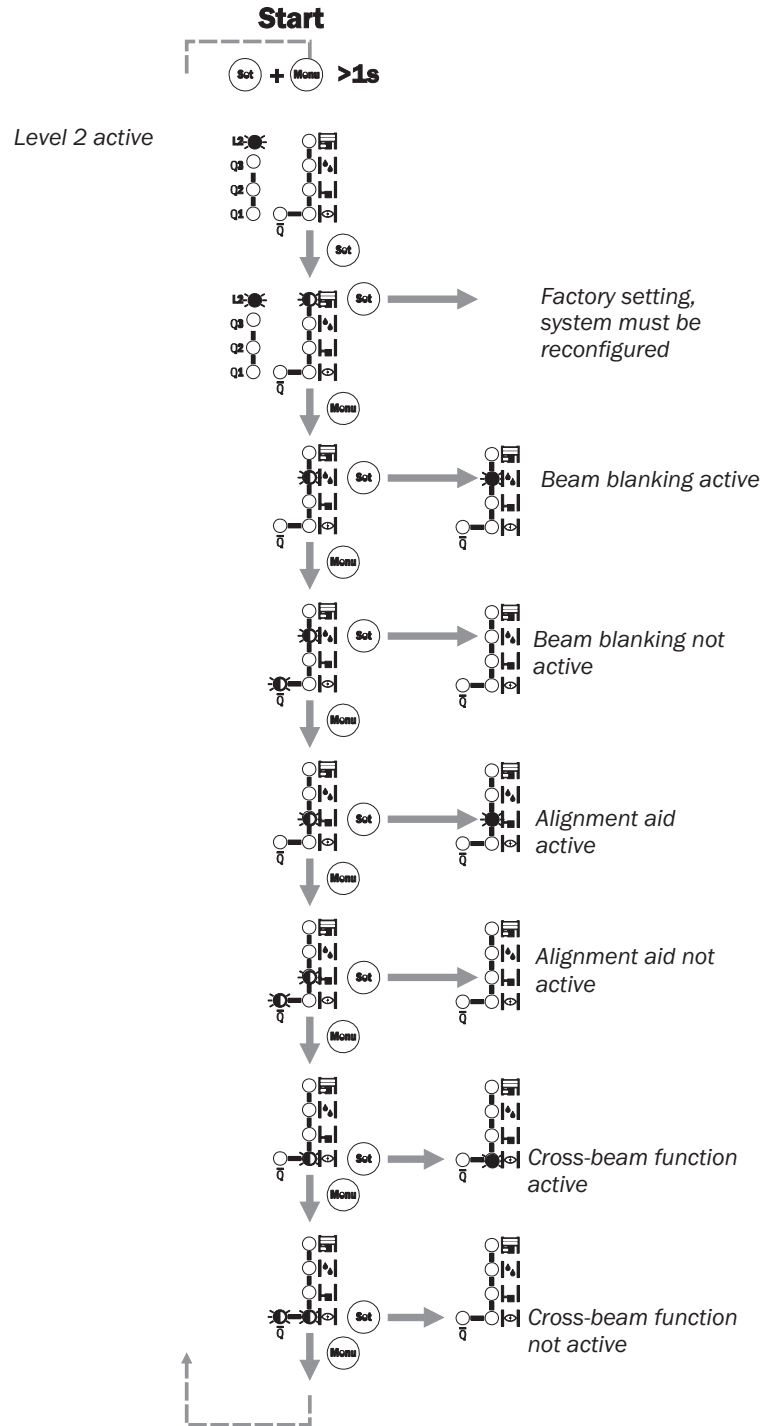

Figure 38: Graph, system settings on operating level 2



NOTE

When the alignment aid is activated, all switching outputs and analog outputs are “frozen” and the process data becomes invalid.

7.2 Measuring functions

7.2.1 Applications for switching outputs

Object detection

The selected output switches when an object is present in the detection area.

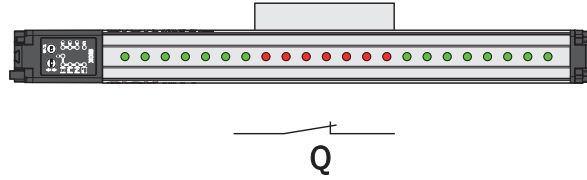

Figure 39: Example of object detection

Contamination warning

The selected output switches when there is a certain level of contamination.

Height classification

When selecting the application, there must be a reference object in the detection area. The MLG-2 defines the maximum object height based on the height of the reference object.

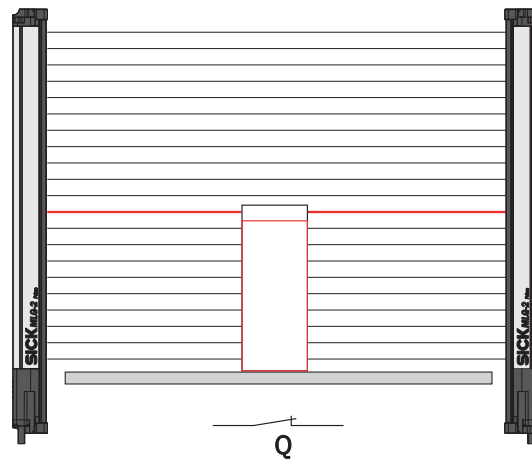

Figure 40: Example of height classification

The selected output switches when an object is larger than the defined object.

The MLG-2 automatically defines the measurement direction and the required beam function.

- If the first beam is blocked, the MLG-2 defines the measurement direction from the bottom.³⁾
- If the last beam is blocked, the MLG-2 defines the measurement direction from the top.

If both the first and last beams are made, the MLG-2 determines the optical center of gravity:

- More beams blocked on the side of the first beam = measurement from the bottom up
- More beams blocked on the side of the last beam = measurement from the top down

³⁾ Applies when light grid is mounted upright with connection side facing down.

Object recognition

When selecting the application, there must be a reference object in the detection area. The MLG-2 memorizes the pattern of the defined objects.

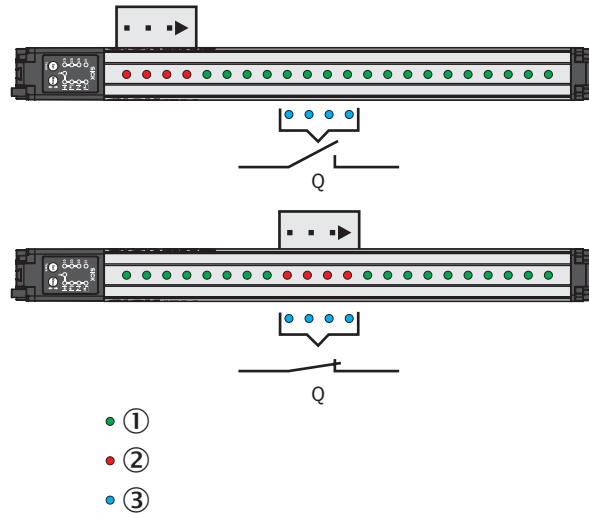

Figure 41: Example for object recognition

- ① Made beams
- ② Blocked beams
- ③ Pattern of defined objects

The selected output switches when the MLG-2 recognizes objects which correspond to the pattern.



NOTE

- This is an example of dynamic object detection, i.e. an object will be recognized at every point in the detection area. The object is allowed to move within the detection area.
- 2 beams are specified as the tolerance.
- An MLG-2 with more than 240 beams can have max. 120 changes (transfer between made and blocked beams).

7.2.2 Applications for analog outputs

FBB – First Beam Blocked

The selected analog output changes its output current with the beam number of the first beam blocked.

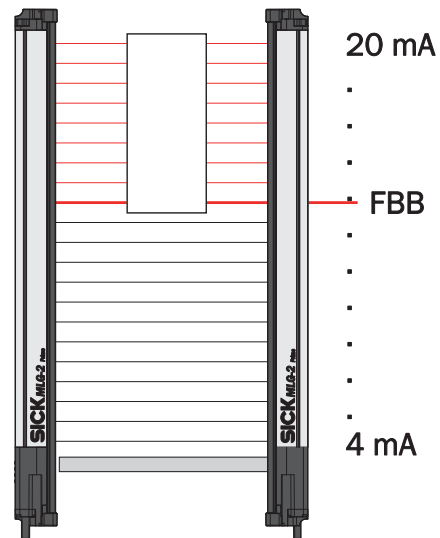

Figure 42: Example for FBB

The higher the beam number of the first beam blocked, the higher the output current.

LBB – Last Beam Blocked

The analog output changes its output current with the beam number of the last beam blocked.

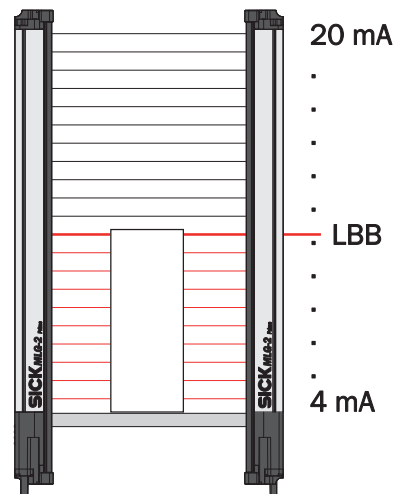

Figure 43: Example for LBB

The higher the beam number of the last beam blocked, the higher the output current.

NBB – Number of Beams Blocked

The analog output changes its output current with the total number of beams blocked.

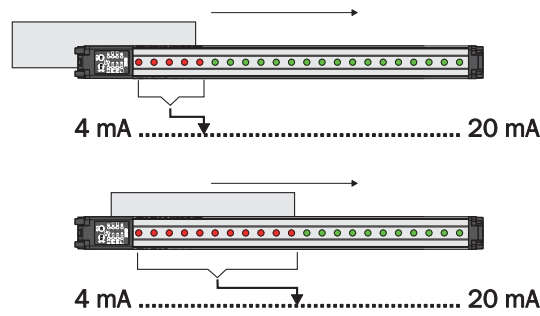

Figure 44: Example for NBB

The more beams blocked, the higher the output current.

It does not matter where in the detection area the beams are blocked. The current increases as the size of the object or the number of objects in the detection area increases.

7.2.3 System settings on operating level 2

Switching to operating level 2

- ▶ Press the **Menu** and **Set** pushbuttons simultaneously for 1 s.
- ✓ ● **L2**: The control panel switches to operating level 2; the LED **L2** lights up.

Quitting operating level 2

- ▶ Do not press any pushbuttons for 15 s.
- ✓ The control panel switches to operating level 1; the LED **L2** goes out.

Reset to the factory setting

This function sets the MLG-2 back to the factory settings. This means that all settings that have been configured are lost.

The alignment aid then becomes active again and a teach-in process must be carried out.

Beam blanking

If certain areas of the detection area are not to be included in the measurement, e.g. because these areas contain the conveying equipment, you can blank these areas using the beam blanking function.

- ▶ Cover the beams that you want to blank.
- ▶ Switch to operating level 2 (press the **Menu** and **Set** pushbuttons simultaneously for 1 s).
- ▶  Select the beam blanking function.

The covered beams will now be permanently blanked throughout the measurement and will no longer be included.



NOTE

When beam blanking is activated, the blocked beams will be blanked for each subsequent teach-in process. It must be ensured that one of the sync beams must be made.

Activate/deactivate alignment aid

The alignment aid is activated at the factory. After the first teach-in process on the MLG-2, the alignment aid is deactivated.

If, at a later date, you want to use the alignment aid again, you can switch it on permanently.

If you do not want to use the alignment aid every time the device is switched on, you can deactivate it again later.

**NOTE**

The digital and analog outputs are deactivated when the alignment aid is active.

Cross-beam function

The cross-beam function increases the measurement accuracy and enables the detection of smaller objects (see "[Minimum detectable object with cross-beam function](#)", page 20).

**NOTE**

The cross-beam function only affects the object detection function, not the measurement functions.

8 IO-Link

The MLG-2 has an IO-Link interface.

8.1 Configuration via acyclic service data

The service data can be used to configure functions such as the alignment aid, teach-in, pushbutton lock, beam blanking, or a change of operating mode. It can also be used to read out the process or teach-in quality, for example.



NOTE

The parameter lists for all readable and writable data are available as separate documents:

- MLG-2 Prime, IO-Link V1.01 (SICK part number 8017123)
- MLG-2 Prime, IO-Link V1.1 (SICK part number 8017184)

8.2 Data storage (IO-Link)

All light grid parameters can be saved in the control system via an IO-Link master using the data storage IO-Link function. If the device is replaced, these parameters can be written to the new device or they can be distributed to multiple MLG-2s with the same application.



NOTE

The device replacement via the IO-Link function data storage is only possible with an MLG-2 with the same part number. This is only valid in conjunction with V1.1.

If the IO-Link master does not support data storage technology, the SICK memory stick (SICK part number 1064290) can provide this functionality (see www.sick.de).

8.3 Output of process data from the MLG-2 Prime

Transmission data

- Cycle time: 6 ms (applies to IO-Link V1.1)
- Frame type: TYPE_2_V
- Data volume (payload): 6 bytes

Data output

The MLG-2 Prime has a fixed process data format:

Byte 0	Byte 1	Bytes 2 and 3	Bytes 4 and 5
Status of the switching outputs Bit 0 ... 2: Q1 ... Q3 Bit 3 ... 7: reserved	System status	Output function 1 (default = NBB)	Output function 2 (default = LBB)

Table 21: Data output of the MLG-2 Prime

On an MLG-2 Prime with analog outputs, the configuration of output functions 1 and 2 determines the content of the process data, as well as the applications of analog outputs 1 and 2.

9 Servicing

The MLG-2 measuring automation light grid is maintenance-free. Depending on the ambient conditions, regular cleaning is required.

Depending on the ambient conditions of the MLG-2, the front screens must be cleaned regularly and in the event of contamination. Static charges can cause dust particles to be attracted to the front screen.



NOTE

- ▶ Do not use aggressive cleaning agents.
 - ▶ Do not use abrasive cleaning agents.
 - ▶ Do not use cleaning agents that contain alcohol, e.g., window cleaner.
-

We recommend anti-static cleaning agents.

We recommend the use of anti-static plastic cleaner (SICK part number 5600006) and the SICK lens cloth (SICK part number 4003353).

How to clean the front screen:

- ▶ Use a clean, soft brush to remove dust from the front screen.
- ▶ Then wipe the front screen with a clean, damp cloth.
- ▶ Check the position of the sender and receiver after cleaning.
- ▶ Perform the teach-in process on the MLG-2 again. To do this, press the **Teach** push-button.

10 Troubleshooting

This chapter describes how to identify faults on the MLG-2.

10.1 Response to faults



CAUTION

Cease operation if the cause of the malfunction has not been clearly identified.

Immediately put the machine out of operation if you cannot clearly identify the fault and if you cannot safely remedy the problem.

10.2 SICK support

If you cannot remedy the error with the help of the information provided in this chapter, please contact your respective SICK subsidiary.

10.3 LED indicators and error indicators

This section explains what the LED error indicators mean. The status indicators are described in a separate section [see "Display and operating elements", page 22](#).

LEDs on the front of the sender

Red LED	Yellow LED	Green LED	Meaning
○	○	○	Supply voltage off or too low
○	○	●	Supply voltage on
○	☉ 1 Hz	●	Test input active
●	○	○	Hardware error

Table 22: LED indicators on the sender

LEDs on the front of the receiver

Red LED	Yellow LED	Green LED	Meaning
○	○	○	Supply voltage off or too low
○	○	●	Supply voltage on
○	●	●	Light path blocked (at least one beam blocked)
○	○	☉ 1 Hz	IO-Link communication
○	☉ 1 Hz	●	Teach-in active
○	☉ 3 Hz	●	Contamination warning or alignment aid active
☉	☉	☉	Find-me function active (only via IO-Link) If multiple MLG-2s are installed in one application, you can activate the "Find Me" function to identify a certain MLG-2.
☉ 10 Hz	●	●	Error occurred during teach-in, at least one beam blocked
●	○	○	Hardware error
●	●	○	Synchronization error: both sync beams blocked
●	○	●	Short-circuit

Table 23: LED indicators on the receiver

11 Decommissioning

11.1 Disposal

Always dispose of serviceableness devices in compliance with local/national rules and regulations with respect to waste disposal.



NOTE

We would be pleased to be of assistance on the disposal of this device. Please contact us.

11.2 Returns

To enable efficient processing and allow us to determine the cause quickly, please include the following when making a return:

- Details of a contact person
- A description of the application
- A description of the fault that occurred

12 Technical data

12.1 Data sheet

General data

Protection class	III (EN 61140)
Enclosure rating	IP 65 and IP 67 (EN 60529) ¹
Class according to UL 60947	Class 2
Ambient operating temperature (UL/CSA: surrounding air temperature)	-30 ... +55 °C
Storage temperature	-40 ... +70 °C
Vibration resistance	Sine-wave vibration 10-150 Hz 5 g
Shock resistance	Continuous shocks 10 g, 16 ms, 1000 shocks Single shocks 15 g, 11 ms, 3 per axis
Electromagnetic compatibility	According to EN 61000-6-2 Interference immunity for industrial environments and EN 61000-6-4 Emission standard for industrial environments
MTTF	15 years
Dimensions	see "Dimensional drawings", page 55
Weight	Sender + receiver approx. 2 kg/m + 0.1 kg
Materials	<ul style="list-style-type: none"> • Housing • Front screen
Firmware version	see "Type labels of the MLG-2 Prime", page 10
	<ul style="list-style-type: none"> • Aluminum, anodized • PMMA

Table 24: MLG-2 data sheet - general data

¹ Do not use light grids outdoors unless protected (condensation will form).

Electrical specifications (for 24 VDC and 25 °C ambient temperature)

Supply voltage V_s	24 VDC \pm 20%
Residual ripple (within V_s)	< 10%
Current consumption of sender	<ul style="list-style-type: none"> • Typical • Maximum
Current consumption of receiver	<ul style="list-style-type: none"> • Typical • MLG-2 Prime maximum
Required overvoltage protection when using the following wire gages	<ul style="list-style-type: none"> • AWG 20/0.52 mm² • AWG 22/0.32 mm² • AWG 24/0.20 mm² • AWG 26/0.13 mm² • AWG 28/0.08 mm² • AWG 30/0.05 mm²
	<ul style="list-style-type: none"> • 40 mA + (0.05 mA \times number of beams) • <55 mA + (0.05 mA \times number of beams) • 80 mA + (0.25 mA \times number of beams) • <100 mA + (0.2 mA \times number of beams) • 5 A • 3 A • 2 A • 1 A • 0.8 A • 0.5 A

Table 25: MLG-2 data sheet - electrical specifications

Inputs

Input voltage	0 V ... V_S
Logic level switching points	
<ul style="list-style-type: none"> HIGH LOW 	<ul style="list-style-type: none"> > 15 V < 5 V

Table 26: MLG-2 data sheet - inputs

Outputs

Switching type	Push-pull
Logic level switching points	
<ul style="list-style-type: none"> HIGH LOW 	<ul style="list-style-type: none"> $V_S - 3\text{ V}$ < 3 V
Maximum output current per output	100 mA
Maximum output load per output	
<ul style="list-style-type: none"> Capacitive Inductive 	<ul style="list-style-type: none"> 100 nF 1 H
Load resistance for analog output 4 ... 20 mA	< 600 Ω
Response time	see figure 45, page 54

Table 27: MLG-2 data sheet - outputs

IO-Link interface

Version	1.1
Data transmission rate	38.4 kbit/s
Maximum length of cable	20 m
Cycle time	
<ul style="list-style-type: none"> MLG-2 Prime 	<ul style="list-style-type: none"> 6 ms
Vendor ID	26
Device ID	
<ul style="list-style-type: none"> MLG-2 Prime 	<ul style="list-style-type: none"> 8388711
Process data	
<ul style="list-style-type: none"> MLG-2 Prime 	<ul style="list-style-type: none"> 6 bytes (TYPE_2_V)¹

Table 28: MLG-2 data sheet - IO-Link interface

¹ For an IO-Link master with V1.0, reverts to interleaved mode (consisting of TYPE_1_1 (process data) and TYPE_1_2 (on-request data)).

Technical measurement data

Wavelength	850 nm
Ambient light immunity	
<ul style="list-style-type: none"> Standard operating mode 	<ul style="list-style-type: none"> 150,000 lx (constant light, indirect)
Minimum detectable object	
<ul style="list-style-type: none"> With parallel-beam function Cross beam function 	<ul style="list-style-type: none"> Beam separation + 4 mm 0.5 × beam separation + 4 mm
Beam separation	5 mm, 10 mm, 20 mm, 25 mm, 30 mm, 50 mm
Number of beams	6 ... 510 mm

Table 29: MLG-2 data sheet - technical measurement specifications

Detection height	130 ... 3140 mm
Limiting range	7 m / 12 m depending on device type
Operating range	5 m / 8.5 m depending on device type
Minimum sensing range <ul style="list-style-type: none"> • With parallel-beam function • With cross-beam function 	<ul style="list-style-type: none"> • At 5 m operating range: 0.2 m / at 8.5 m operating range: 0.5 m • 0.11 ... 1.20 m (see table 30, page 54)
Initialization time after switch-on	<1 s
Response time	see "MLG-2 Prime response time and minimum presence time", page 54
Minimum presence time	see "MLG-2 Prime response time and minimum presence time", page 54
Cycle time	32 µs per beam ¹

Table 29: MLG-2 data sheet - technical measurement specifications

¹ Depending on device version and operating mode.

MLG-2 with sensing range	Raster					
	5 mm	10 mm	20 mm	25 mm	30 mm	50 mm
5 m	0.11 m	0.22 m	0.44 m	0.55 m	0.66 m	1.10 m
8.5 m	0.12 m	0.24 m	0.48 m	0.60 m	0.72 m	1.20 m

Table 30: Minimum sensing range with cross-beam function

12.2 Diagrams

12.2.1 MLG-2 Prime response time and minimum presence time

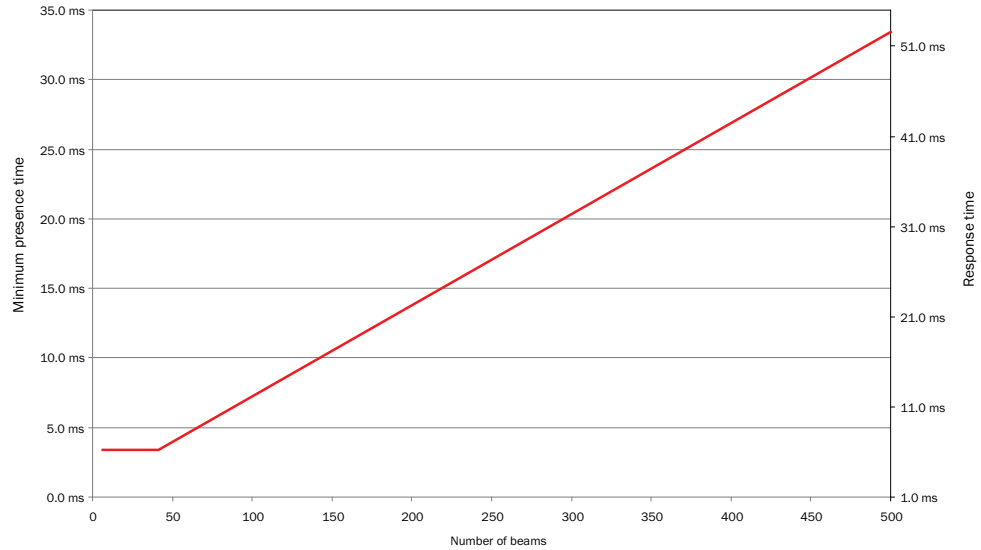

Figure 45: Graph, MLG-2 Prime response time and minimum presence time



NOTE

If the cross-beam function is configured, multiply the minimum presence time and the response time by 2.

12.3 Dimensional drawings

12.3.1 MLG-2 Prime dimensional drawing

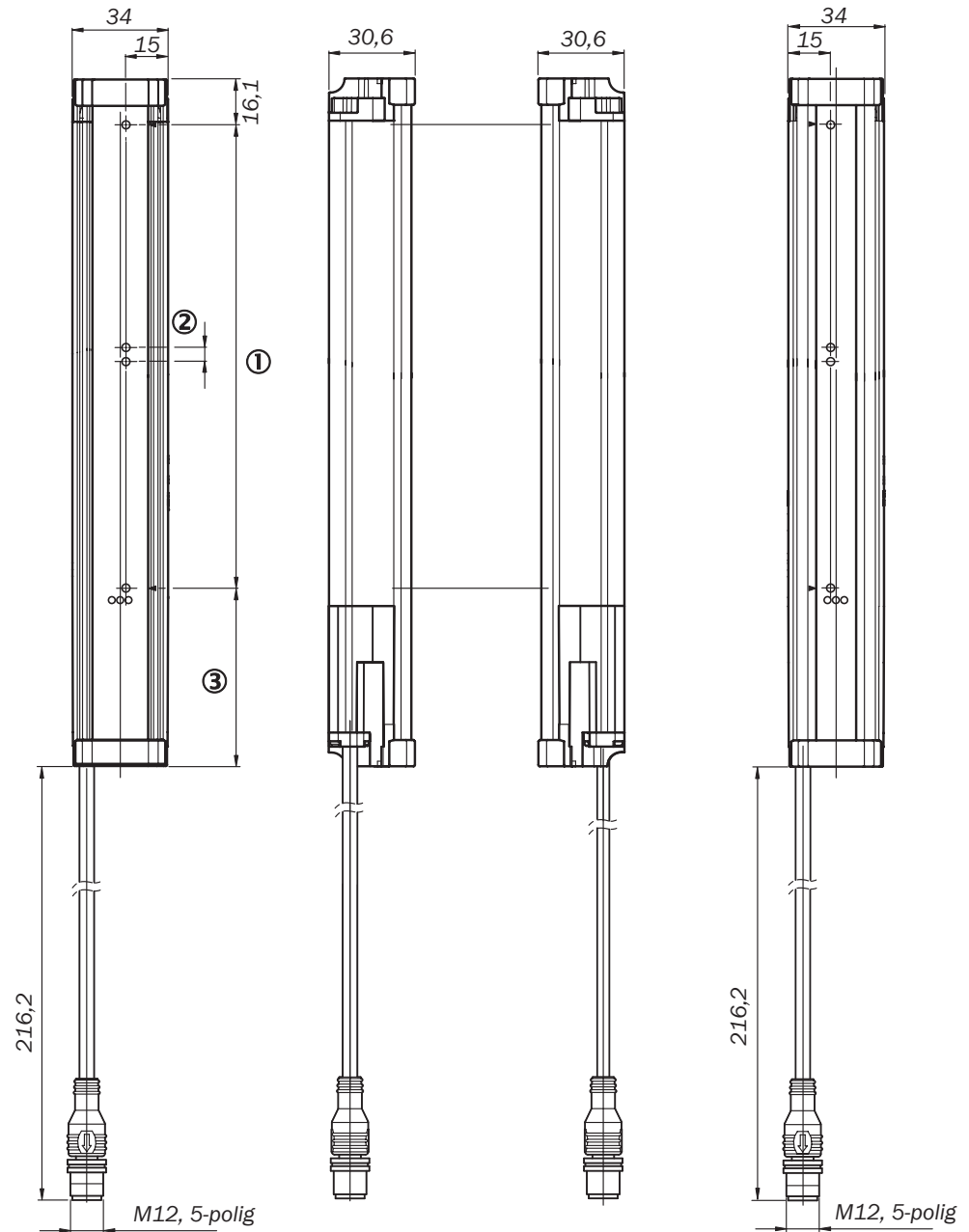

Figure 46: MLG-2 Prime (mm) dimensional drawing

- ① Monitoring height⁴⁾ = (n × SA) - 1 SA
 - ② Beam separation (SA)
 - ③ Distance from MLG-2 edge to first beam (see table 32, page 56)
- Total height = ① + ③ + 16,1 mm

4) See type code.

12.3.2 Measurement tables

	Type/beam separation					
	MLG05.../ 5 mm	MLG10.../ 10 mm	MLG20.../ 20 mm	MLG25.../ 25 mm	MLG30.../ 30 mm	MLG50.../ 50 mm
Monitoring height [mm]/ number of beams	145/30	140/15	140/8 *	-	-	-
	295/60	290/30	280/15	275/12	270/10	250/6
	445/90	440/45	440/23 *	425/18	420/15	400/9
	595/120	590/60	580/30	575/24	570/20	550/12
	745/150	740/75	740/38 *	725/30	720/25	700/15
	895/180	890/90	880/45	875/36	870/30	850/18
	1045/210	1040/105	1040/53 *	1025/42	1020/35	1000/21
	1195/240	1190/120	1180/60	1175/48	1170/40	1150/24
	1345/270	1340/135	1340/68 *	1325/54	1320/45	1300/27
	1495/300	1490/150	1480/75	1475/60	1470/50	1450/30
	1645/330	1640/165	1640/83 *	1625/66	1620/55	1600/33
	1795/360	1790/180	1780/90	1775/72	1770/60	1750/36
	1945/390	1940/195	1940/98 *	1925/78	1920/65	1900/39
	2095/420	2090/210	2080/105	2075/84	2070/70	2050/42
	2245/450	2240/225	2240/113 *	2225/90	2220/75	2200/45
	2395/480	2390/240	2380/120	2375/96	2370/80	2350/48
	2545/510	2540/255	2540/128 *	2525/102	2520/85	2500/51
	-	2690/270	2680/135	2675/108	2670/90	2650/54
-	2840/285	2840/143 *	2825/114	2820/95	2800/57	
-	2990/300	2980/150	2975/120	2970/100	2950/60	
-	3140/315	3140/158 *	3125/126	3120/105	3100/63	

Table 31: Monitoring height (mm)/number of beams

Beam separation	Distance from MLG-2 edge to first beam
5 mm	63.3 mm
10 mm	68.3 mm
20 mm	68.3 mm (*), otherwise 78.3 mm
25 mm	83.3 mm
30 mm	88.3 mm
50 mm	108.3 mm

Table 32: Distance from MLG-2 edge to first beam

13 **Ordering information**

The ordering information for the MLG-2 can be found in the MLG-2 product information with the SICK part number 8017054.

14 Accessories

Type	Description	Part no.
AR60	Laser alignment aid for various sensors, laser class 2 (IEC 60825): Do not look into the beam.	1015741
Adapter AR60	Adapter AR60 for MLG-2	4070854
Lens cloth	Cloth for cleaning the front screen	4003353
Plastic cleaner	Plastic cleaner and polish, anti-static, 0.5 liters	5600006

Table 33: Accessory part numbers

Type	Description	Part no.
BEF-1SHABP004	Mounting kit for replacement of swivel mount brackets 2019649 and 2019659 or side bracket 2019506 with the FlexFix bracket when using the bore holes provided	2071021
BEF-1SHABPKU4	FlexFix bracket, plastic	2066614
BEF-3SHABPKU2	QuickFix bracket, plastic	2066048

Table 34: Mounting material part numbers

Type	Description	Part no.
SiLink2 Master	IO-Link V1.1 port class A, USB2.0 connection, optional external power supply 24 V/1 A	1061790
SICK Memory Stick	IO-Link version V1.1, port class 2, PIN 2, 4, 5 galvanically connected, 18 V DC ... 32 V DC supply voltage (limit values during operation in short-circuit protected network, max. 8 A)	1064290

Table 35: Connection module part numbers

Type	Description	Part no.
T-nuts	Sliding nut	4031411
Sliding nut	Sliding nut, M5	5305719
Sliding nuts	Sliding nut set, M5, 4 pieces	2017550
UH sliding nut	Sliding nut, item profile, M6	5305615

Table 36: Sliding nut part numbers

Type	Head A connection type	Head B connection type	Connecting cable	Part no.
DOL-1205-G05MAC	Female connector, M12, 5-pin, straight screened	Cable, flying leads	5 m, 5-wire	6036384
DOL-1205-G02M	Female connector, M12, 5-pin, straight unscreened	Cable, flying leads	2 m, 5-wire	6008899
DOL-1205-G05M			5 m, 5-wire	6009868
DOL-1205-G10M			10 m, 5-wire	6010544
DOL-1205-G15M			15 m, 5-wire	6029215

Table 37: Part numbers for connecting cable with female connector

Type	Head A connection type	Head B connection type	Part no.
DOS-1208-GA	Female connector, M12, 8-pin, straight, shielded	Screw terminals	6028369

Table 38: Female and male connector part numbers

Type	Head A connection type	Head B connection type	Part no.
STE-1205-G	Male connector, M12, 5-pin, straight, unshielded	Screw terminals	6022083

Table 38: Female and male connector part numbers

Type	Head A connection type	Head B connection type	Connecting cable	Part no.
DSL-1205-G01MC	Male connector, M12, 5-pin, straight unshielded	Female connector, M12, 5-pin, straight	1 m, 5-wire	6029280
DSL-1205-G02MC			2 m, 5-wire	6025931
DSL-1205-G05MC			5 m, 5-wire	6029282
DSL-1205-G10MC			10 m, 5-wire	6038954

Table 39: Part numbers for connecting cable with male/female connector

15 Annex

15.1 Compliance with EU directive

EU declaration of conformity (extract)

The undersigned, who represents the manufacturer below, hereby declares that the product complies with the regulations of the EU directive(s) below (including all relevant changes), and that it is based on the relevant standards and/or technical specifications.

Complete EU declaration of conformity for download: www.sick.de

16 List of figures

1.	Type label of sender.....	10
2.	Type label of receiver.....	10
3.	MLG-2 Prime.....	14
4.	Detection area of the MLG-2.....	15
5.	Schematic representation of available beam separations (mm).....	16
6.	Detection area with beams blanked.....	17
7.	Standard scan method.....	18
8.	Scan time in relation to the number of beams.....	18
9.	Cross-beam function.....	19
10.	Minimum detectable object.....	19
11.	Minimum detectable object length.....	20
12.	Cross-beam function.....	21
13.	LEDs on the sender.....	23
14.	LEDs on the front of the receiver.....	23
15.	MLG-2 Prime control panel with switching outputs.....	24
16.	MLG-2 Prime control panel with analog outputs and switching output.....	24
17.	Height classification and overhang measurement.....	25
18.	Position detection on a conveyor belt.....	25
19.	Slack regulation.....	25
20.	Access control.....	25
21.	Placement with light in opposite directions.....	26
22.	Distances when light is in the same direction.....	27
23.	Graph, distances when light is in the same direction.....	28
24.	Graph, minimum distance from reflective surfaces.....	29
25.	The sender and receiver are aligned incorrectly.....	30
26.	Mount QuickFix bracket to a profile frame.....	31
27.	Mounting the FlexFix bracket on a profile frame.....	32
28.	Inserting the MLG-2 in the FlexFix brackets.....	32
29.	Alignment with the QuickFix bracket.....	35
30.	Alignment with the FlexFix bracket.....	36
31.	Rotate the receiver once.....	36
32.	Alignment aid - LEDs alignment quality.....	37
33.	Control panel with LEDs and membrane keys.....	38
34.	of the MLG-2 Prime with switching outputs.....	38
35.	MLG-2 Prime control panel with analog outputs and switching output.....	38
36.	Graph, setting the output and application for MLG-2 Prime with switching outputs	40
37.	Graph, setting the output and application for MLG-2 Prime with analog outputs and switching output.....	41
38.	Graph, system settings on operating level 2.....	42
39.	Example of object detection.....	43
40.	Example of height classification.....	43
41.	Example for object recognition.....	44
42.	Example for FBB.....	45
43.	Example for LBB.....	45
44.	Example for NBB.....	46
45.	Graph, MLG-2 Prime response time and minimum presence time.....	54
46.	MLG-2 Prime (mm) dimensional drawing.....	55

17 List of tables

1.	Authorized personnel.....	8
2.	Example of an MLG-2 Prime type code.....	10
3.	Meaning of the positions in the type code.....	10
4.	MLG-2 Prime (mm) monitoring height.....	11
5.	Possible combinations of MLG-2 Prime inputs and outputs.....	11
6.	MLG-2 Prime sensing range and minimum detectable object length.....	12
7.	Preconfiguration of MLG-2 Prime with I/O combination A (see table 5, page 11). 12	12
8.	Preconfiguration of MLG-2 Prime with I/O combination D (see table 5, page 11) 12	12
9.	Maximum detection heights.....	16
10.	Limiting range.....	17
11.	Minimum detectable object depends on the MLG-2 Prime beam separation.....	20
12.	Minimum detectable object length for the MLG-2 Prime.....	20
13.	Minimum detectable object during MLG-2 Prime cross-beam function.....	21
14.	Configurable applications for switching outputs.....	22
15.	Application examples for the MLG-2 Prime.....	25
16.	Overcurrent protection.....	33
17.	Pin assignment, MLG-2 Prime sender.....	33
18.	Pin assignment, I/O, MLG2 Prime receiver with Q.....	34
19.	Pin assignment, I/O, MLG2 Prime receiver with QA.....	34
20.	Meaning of the displays.....	39
21.	Data output of the MLG-2 Prime.....	48
22.	LED indicators on the sender.....	50
23.	LED indicators on the receiver.....	50
24.	MLG-2 data sheet - general data.....	52
25.	MLG-2 data sheet - electrical specifications.....	52
26.	MLG-2 data sheet - inputs.....	53
27.	MLG-2 data sheet - outputs.....	53
28.	MLG-2 data sheet - IO-Link interface.....	53
29.	MLG-2 data sheet - technical measurement specifications.....	53
30.	Minimum sensing range with cross-beam function.....	54
31.	Monitoring height (mm)/number of beams.....	56
32.	Distance from MLG-2 edge to first beam.....	56
33.	Accessory part numbers.....	58
34.	Mounting material part numbers.....	58
35.	Connection module part numbers.....	58
36.	Sliding nut part numbers.....	58
37.	Part numbers for connecting cable with female connector.....	58
38.	Female and male connector part numbers.....	58
39.	Part numbers for connecting cable with male/female connector.....	59

Australia

Phone +61 3 9457 0600
1800 334 802 - tollfree
E-Mail sales@sick.com.au

Austria

Phone +43 22 36 62 28 8-0
E-Mail office@sick.at

Belgium/Luxembourg

Phone +32 2 466 55 66
E-Mail info@sick.be

Brazil

Phone +55 11 3215-4900
E-Mail marketing@sick.com.br

Canada

Phone +1 905 771 14 44
E-Mail information@sick.com

Czech Republic

Phone +420 2 57 91 18 50
E-Mail sick@sick.cz

Chile

Phone +56 2 2274 7430
E-Mail info@schadler.com

China

Phone +86 20 2882 3600
E-Mail info.china@sick.net.cn

Denmark

Phone +45 45 82 64 00
E-Mail sick@sick.dk

Finland

Phone +358-9-2515 800
E-Mail sick@sick.fi

France

Phone +33 1 64 62 35 00
E-Mail info@sick.fr

Germany

Phone +49 211 5301-301
E-Mail info@sick.de

Hong Kong

Phone +852 2153 6300
E-Mail ghk@sick.com.hk

Hungary

Phone +36 1 371 2680
E-Mail office@sick.hu

India

Phone +91 22 4033 8333
E-Mail info@sick-india.com

Israel

Phone +972 4 6881000
E-Mail info@sick-sensors.com

Italy

Phone +39 02 274341
E-Mail info@sick.it

Japan

Phone +81 3 5309 2112
E-Mail support@sick.jp

Malaysia

Phone +6 03 8080 7425
E-Mail enquiry.my@sick.com

Mexico

Phone +52 472 748 9451
E-Mail mario.garcia@sick.com

Netherlands

Phone +31 30 2044 000
E-Mail info@sick.nl

New Zealand

Phone +64 9 415 0459
0800 222 278 - tollfree
E-Mail sales@sick.co.nz

Norway

Phone +47 67 81 50 00
E-Mail sick@sick.no

Poland

Phone +48 22 539 41 00
E-Mail info@sick.pl

Romania

Phone +40 356 171 120
E-Mail office@sick.ro

Russia

Phone +7 495 775 05 30
E-Mail info@sick.ru

Singapore

Phone +65 6744 3732
E-Mail sales.gsg@sick.com

Slovakia

Phone +421 482 901201
E-Mail mail@sick-sk.sk

Slovenia

Phone +386 591 788 49
E-Mail office@sick.si

South Africa

Phone +27 11 472 3733
E-Mail info@sickautomation.co.za

South Korea

Phone +82 2 786 6321
E-Mail info@sickkorea.net

Spain

Phone +34 93 480 31 00
E-Mail info@sick.es

Sweden

Phone +46 10 110 10 00
E-Mail info@sick.se

Switzerland

Phone +41 41 619 29 39
E-Mail contact@sick.ch

Taiwan

Phone +886 2 2375-6288
E-Mail sales@sick.com.tw

Thailand

Phone +66 2645 0009
E-Mail Ronnie.Lim@sick.com

Turkey

Phone +90 216 528 50 00
E-Mail info@sick.com.tr

United Arab Emirates

Phone +971 4 88 65 878
E-Mail info@sick.ae

United Kingdom

Phone +44 1727 831121
E-Mail info@sick.co.uk

USA

Phone +1 800 325 7425
E-Mail info@sick.com

Vietnam

Phone +84 945452999
E-Mail Ngo.Duy.Linh@sick.com

Further locations at www.sick.com