



Software manual  
ifm Vision Assistant  
for multicode reader  
**O2I5xx**

**UK**

## Content

1	Preliminary note	5
1.1	Symbols used	5
1.2	Safety instructions	5
1.3	Further documents	5
1.4	Open source information	6
2	System requirements	7
2.1	Software	7
2.2	Hardware and accessories	7
3	Installation	8
3.1	Software	8
3.2	Hardware	8
4	Command line parameters	9
5	Start screen	10
5.1	Find device and connect	11
5.1.1	Manual connection	12
5.2	Recently used	12
5.3	Options after connection	13
5.4	Replay	13
5.5	Device status	14
5.6	Wiring	14
5.7	Settings	14
5.8	Help	14
6	Structure of the user interface	15
6.1	Navigation bar	16
6.2	Main area	16
6.3	Status bar	16
7	Monitoring	17
7.1	Status displays	17
7.2	View options	18
7.3	Results	18
7.4	Code details	19
8	Application management	20
9	Edit application	22
9.1	Activate the area "Edit application"	22
9.2	Live image	23
9.2.1	Create region of interest (ROI)	24
9.2.2	Create region of disinterest (ROD)	25
9.3	Images & trigger	26
9.3.1	Trigger mode	27
9.3.2	Frame rate	27
9.3.3	Focus	27
9.3.4	Add new image	29
9.3.5	Exposure time	30
9.3.6	Analogue gain factor	30
9.3.7	Illumination	30
9.3.8	Filter type	30
9.3.9	Filter strength	31
9.3.10	Invert filter	31
9.4	Model settings	32
9.4.1	Add new model	33
9.4.2	Code types	33
9.4.3	Model with 1D barcode	34
9.4.4	Encoding	34
9.4.5	Number of codes per ROI group	35
9.4.6	Timeout	35
9.4.7	Measure ISO quality	36

9.4.8	Minimum contrast	37
9.4.9	Min. code length	37
9.4.10	Quiet zone	37
9.4.11	Alignment	39
9.4.12	Orientation tolerance	39
9.4.13	Number of scanlines	39
9.4.14	Majority voting	40
9.4.15	Merge scanlines	40
9.4.16	Minimum identical scanlines	41
9.4.17	Start/Stop tolerance	41
9.4.18	Element size variable	41
9.4.19	Barcode height min.	42
9.4.20	Barcode width min	42
9.4.21	Model with 2D DataCode	43
9.4.22	Presets	44
9.4.23	Encoding	44
9.4.24	Number of codes per ROI group	44
9.4.25	Timeout	44
9.4.26	Quality grading	45
9.4.27	Polarity	47
9.4.28	Strict quiet zone	47
9.4.29	Contrast tolerance	47
9.4.30	Finder pattern tolerance	47
9.4.31	Module grid	48
9.4.32	Max slant	48
9.4.33	Mirrored	48
9.4.34	Symbol shape	49
9.4.35	Symbol columns min	49
9.4.36	Symbol columns max	50
9.4.37	Symbol rows min	50
9.4.38	Symbol rows max	50
9.4.39	Minimum symbol size	51
9.4.40	Maximum symbol size	51
9.5	Flow	52
9.5.1	Display flow chart	52
9.5.2	Set flow settings	53
9.5.3	Set the position of an image	53
9.5.4	Activate or deactivate image	53
9.5.5	Delete image	53
9.5.6	Set position of a model	53
9.5.7	Connect model with image	54
9.5.8	Delete model	54
9.5.9	Set timeout for a model	54
9.6	Logic	55
9.6.1	Logic blocks	55
9.6.2	Main area	55
9.6.3	Overview area	55
9.6.4	Create output logic	56
9.6.5	Place logic block in the main area	56
9.6.6	Set logic block	57
9.6.7	Delete logic block	57
9.6.8	Connect logic block	57
9.6.9	Delete connecting lines	57
9.6.10	Description of the logic blocks "Model results"	58
9.6.11	Description of the logic block "Application result"	62
9.6.12	Description of the logic blocks "String operations"	63
9.6.13	Description of the logic blocks "Arithmetic"	64
9.6.14	Description of the logic blocks "Digitalisation"	64
9.6.15	Description of the logic blocks "Logical functions"	64
9.6.16	Description of the logic blocks "Output"	65
9.6.17	Description of the logic blocks "Pin Events"	65
9.6.18	Description of the logic blocks "Statistics"	65



9.6.19	Example 1 of "Compare reference code" . . . . .	66
9.6.20	Example 2 of "Compare reference code" . . . . .	66
9.6.21	Example 3 of "Compare reference code" . . . . .	67
9.7	Interfaces . . . . .	68
9.7.1	Settings . . . . .	68
9.7.2	Main area . . . . .	69
9.7.3	Output string . . . . .	69
9.7.4	Overview area . . . . .	69
9.7.5	Insert data package . . . . .	70
9.7.6	Show and hide loops . . . . .	71
9.7.7	Set data package . . . . .	71
9.7.8	Delete data package . . . . .	71
9.7.9	Example for "Provide overall quality" . . . . .	71
9.8	Test . . . . .	72
9.8.1	Start test . . . . .	72
9.8.2	Stop test . . . . .	73
9.8.3	Test images . . . . .	73
9.8.4	Show test image . . . . .	73
9.8.5	Overall statistics . . . . .	73
9.8.6	Reset overall statistics . . . . .	73
10	Device set-up . . . . .	74
10.1	General . . . . .	75
10.2	Network . . . . .	76
10.3	Interfaces . . . . .	77
10.4	NTP . . . . .	78
10.5	FTP . . . . .	78
10.6	ifm storage device . . . . .	80
11	Appendix . . . . .	81
11.1	Network settings . . . . .	81
11.2	Error messages . . . . .	84
11.2.1	Firmware update . . . . .	84
11.3	Glossary . . . . .	85

**Copyright**

Microsoft®, Window®, Windows 7®, Windows 8®, Windows 8.1® and Windows 10® are registered trademarks of Microsoft Corporation.

Adobe® and Acrobat® are registered trademarks of Adobe Systems Inc.

All trademarks and company names used are subject to the copyright of the respective companies.

# 1 Preliminary note

The software manual describes the functions of the O2I50x multicode reader in connection with the ifm Vision Assistant software:

- Parameter setting of the O2I50x multicode reader (in the following referred to as "device")
- Setting up applications with the ifm Vision Assistant
- Monitoring applications with the ifm Vision Assistant



The ifm Vision Assistant is used for parameter setting and monitoring of the following products:

- O2I50x multicode reader
- O3D3xx 3D sensor and 3D camera
- O3Mxxx 3D sensor for mobile applications
- O3Xxxx 3D camera
- ZB086x Ethernet camera

## 1.1 Symbols used

- ▶ Instruction
- > Reaction, result
- [...] Designation of keys and buttons
- "..." Name of display text
- Cross-reference



Important note  
Non-compliance may result in malfunction or interference.



Information  
Supplementary note

## 1.2 Safety instructions

Please read the operating instructions prior to set-up of the device. Ensure that the product is suitable for your application without any restrictions.

If the operating instructions or the technical data are not adhered to, personal injury and/or damage to property can occur.

## 1.3 Further documents

- Quick reference guide
- Operating instructions



The documents can be downloaded at:  
[www.ifm.com](http://www.ifm.com)

## 1.4 Open source information

This product can contain Free Software or Open Source Software from various software developers which is subject to the following licenses: General Public License version 1, version 2 and version 3 (General Public License version 3 in conjunction with the GNU Compiler Collection Runtime Library Exception version 3.1), Lesser General Public License version 2.1, Lesser General Public License version 3, Berkeley Software Distribution ("This product includes software developed by the University of California, Berkeley and its contributors"), The Academic Free License version 2.1. For the components subject to the General Public License in their respective versions the following applies:

This program is free software: you can redistribute it and/or modify it under the terms of the GNU General Public License as published by the Free Software Foundation. If version 1 applies to the software: either version 1 of the License or (at your option) any later version; if version 2 (or 2.1) applies to the software: either version 2 (or 2.1) of the License or (at your option) any later version; if version 3 applies to the software: either version 3 of the License or (at your option) any later version. The following disclaimer of the software developers applies to the software components that are subject to the General Public License or the Lesser General Public License in their respective versions: The Free Software is distributed in the hope that it will be useful, but WITHOUT ANY WARRANTY; without even the implied warranty of MERCHANTABILITY or FITNESS FOR A PARTICULAR PURPOSE. See the GNU General Public License and the GNU Lesser General Public License for more details.

The responsibility of ifm electronic gmbh for ifm products, in the case of product-specific software, remains unaffected by the above disclaimer. Please note that the firmware for the ifm products is in some cases provided free of charge. The price of the ifm products has then to be paid for the respective device itself (hardware) and not for the firmware. For the latest information on the license agreement for your product please visit [www.ifm.com](http://www.ifm.com)

For binaries that are licensed under any version of the GNU General Public License (GPL) or the GNU LGPL you may obtain the complete corresponding source code of the GPL software from us by sending a written request to: [opensource@ifm.com](mailto:opensource@ifm.com) or to ifm electronic gmbh Friedrichstraße 1, 45128 Essen, Germany.

We charge €30 for each request. Please write "source for product Y" in the memo line of your payment. Your request should include (i) the name of the covered binary, (ii) the name and the version number of the ifm product, (iii) your name and (iv) your return address.

This offer is valid to anyone in receipt of this information.

This offer is valid for at least three years (from the date you received the GLP/LGPL covered code).

## 2 System requirements

### 2.1 Software

- Operating system: Windows 7 (32/64 bit), Windows 8.1 (32/64 bit), Windows 10 (32/64 bit)
- Application software: ifm Vision Assistant 2.0.46
- Firmware of the device: 1.1.4826



Other versions of the ifm Vision Assistant may contain changed or new functions which are not described in this software manual.

### 2.2 Hardware and accessories

#### Hardware

- Sensor of the O2I50x family
- PC with x86 or x64 type processor
- Screen: min. 1024 x 768 pixels, 32-bit colour depth

#### Accessories

- Cable for the network connection (Ethernet) for setting the parameters:
  - E11898 (2 m, M12 plug/RJ45 plug, 4 poles)
  - E12283 (5 m, M12 plug/RJ45 plug, 4 poles)
- Connection cable for voltage supply and process connection:
  - EVC070 (2 m, M12 socket, 5 poles, open cable end)
  - EVC071 (5 m, M12 socket, 5 poles, open cable end)
- Y connection cables:
  - EVC847 (splitter for camera and external trigger)
  - EVC848 (splitter for camera and external illumination unit)
- 24 V power supply, 1.6 A, maximum current consumption 0.4 A
- Mounting set for the device (clamp mounting) E2D500



The cables shown represent only a selection. More accessories at: [www.ifm.com](http://www.ifm.com)

## 3 Installation

### 3.1 Software

The ifm Vision Assistant software configures, programs and monitors the device.

Install the ifm Vision Assistant:

- ▶ Insert the data carrier with the ifm Vision Assistant software.  
Alternatively: Download the ifm Vision Assistant software from the website: [www.ifm.com](http://www.ifm.com)
- ▶ Copy the zip file "ifmVisionAssistant" to an appropriate directory on the PC and unzip.
- ▶ Start the "ifmVisionAssistant" application file.



When a high-resolution monitor (> 2560x1140 pixels) is used:

- ▶ Start the application file "iVA\_on\_highdpi\_display".
- > The start page of the ifm Vision Assistant opens.

If the ifm Vision Assistant does not open after 5 - 10 seconds:

- ▶ Check the system requirements for the software (→ 2.1 Software).
- ▶ Check if all files are properly unzipped.

### 3.2 Hardware

The installation and set-up of the device is described in the operating instructions (→ Operating instructions).



## 4 Command line parameters

Starting the ifm Vision Assistant is influenced by command line parameters.

Start the ifm Vision Assistant via the prompt:

- ▶ In the prompt, enter parameter after "ifmVisionAssistant.exe" separated by a space.
- > Example: "ifmVisionAssistant.exe -log"

Start the ifm Vision Assistant via the Windows graphical user interface:

- ▶ Right-click the shortcut of the [ifm Vision Assistant].
- ▶ Click [Properties] in the submenu.
- ▶ Click tab [Shortcut]
- ▶ Click the field [Target] and move the cursor to the end of the line.
- ▶ Enter space followed by the command line parameter.
- ▶ Click [OK].

The following command line parameters are available:

Command line parameters	Description
-disableclosebtn	Disables the button [Close] on the start page.
-log	Creates a log file for a detailed fault analysis. The log file is saved in the following folder: "%APPDATA%\ifm electronic\ifmVisionAssistant\logs"
-autoconnect filename.xml	Automatically connects to a device. The file "filename.xml" must contain the following XML code: <pre>&lt;?xml version="1.0" encoding="UTF-8"?&gt; &lt;sensor&gt;   &lt;sensorType&gt;O2I5xx&lt;/sensorType&gt;   &lt;addressType&gt;IP&lt;/addressType&gt;   &lt;name&gt;My sensor&lt;/name&gt;   &lt;address&gt;     &lt;ip&gt;192.168.0.69&lt;/ip&gt;     &lt;pcic_port&gt;50010&lt;/pcic_port&gt;     &lt;web_port&gt;80&lt;/web_port&gt;     &lt;mac&gt;00:02:01:21:b9:ee&lt;/mac&gt;   &lt;/address&gt; &lt;/sensor&gt;</pre>
-geometry [screen]:[width]x[height]+[x]+[y]	Sets the window size and position of the ifm Vision Assistant (incl. Windows frame). The minimum window size is 1024x768 pixels. Example: "-geometry 1:1380x768+0+0" The window is placed on screen 1 (screen=1). The window size incl. Windows window frame is set to 1380x768 (width = 1380 and height = 768). The window is positioned at the top left (x=0 and y=0). When negative values are entered for the window position x and y, the opposite corner is used as zero point. Example: "+0+0" window at the top left "-0+0" window at the top right "+0-0" window at the bottom left "-0-0" window at the bottom right
-frameless	Starts the ifm Vision Assistant without the native window frame.

## 5 Start screen

The basic functions of the ifm Vision Assistant are selected on the start page.

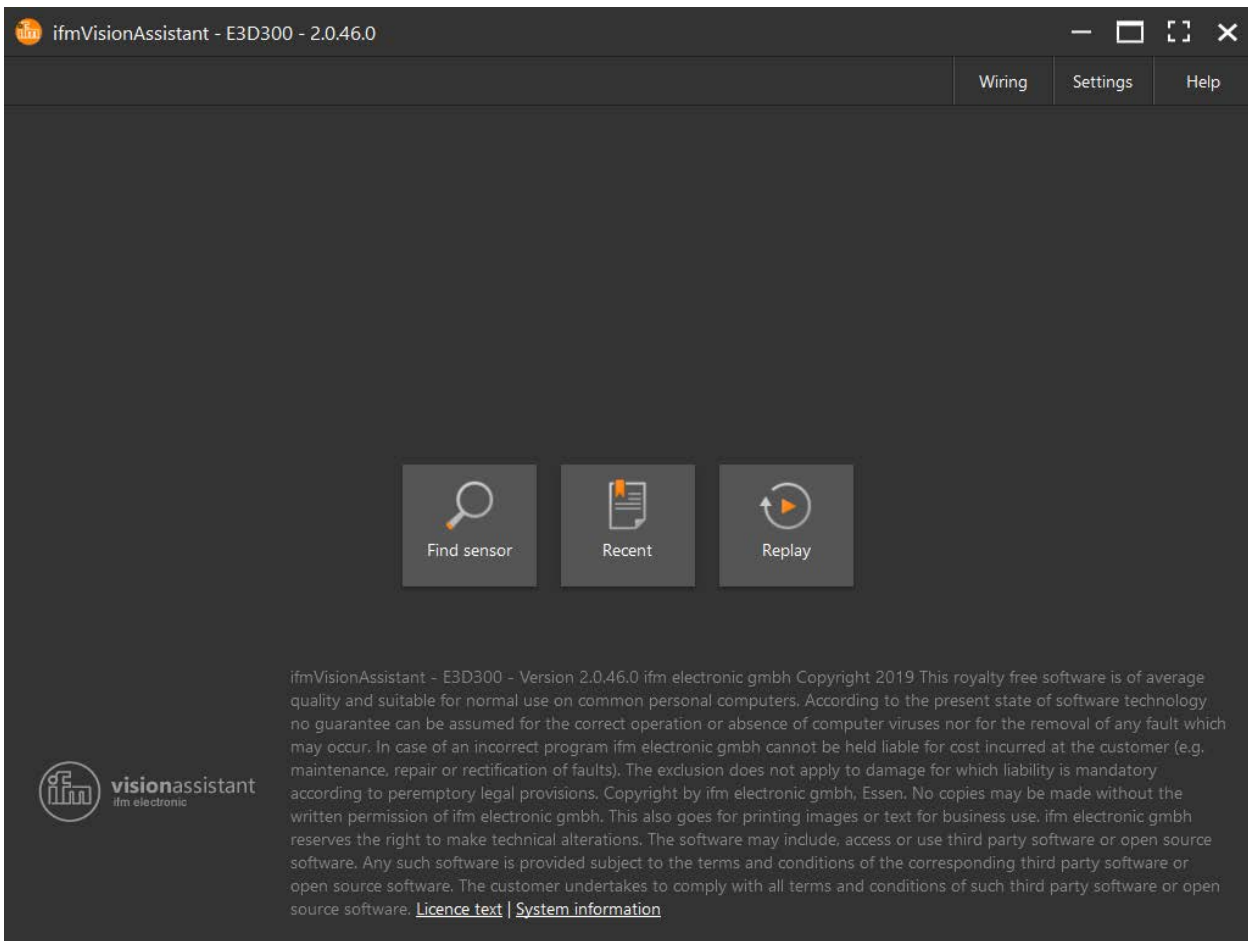

Functions in the title bar:

Symbol	Name	Function	Device must be connected
—	Zoom out	Reduces the window of the ifm Vision Assistant.	No
□	Zoom in	Enlarges the window of the ifm Vision Assistant.	No
⌘	Full screen	Displays the window of the ifm Vision Assistant in full screen mode.	No
×	Exit	Exits the ifm Vision Assistant.	No





With the F11 key, you can switch between full screen and window view at any time.

Functions in the menu bar:

Name	Function	Device must be connected
Device status	<p>The menu [Device status] displays information about the hardware and firmware of the connected device (→ 5.5 Device status).</p> <p> The menu [Device status] is displayed when a device is connected.</p>	Yes

Name	Function	Device must be connected
<b>Wiring</b>	The menu [Wiring] displays information about the wiring of the device.(→ 5.6 Wiring).	No
<b>Settings</b>	In the menu [Settings], the language of the user interface is set (→ 5.7 Settings).	No
<b>Help</b>	The menu [Help] displays the documentation and contact information about the central and local manufacturer support (→ 5.8 Help).	No

Functions as symbol:

Symbol	Name	Function	Device must be connected
	Find sensor	Connect a new device. Searches for connected devices and displays a selection list of the devices found (→ 5.1 Find device and connect).	Yes
	Recently used	Connect a device which was connected before. Opens a selection list of the devices which have been connected before (→ 5.2 Recently used).	Yes
	Replay	Plays back recorded sequences (→ 5.4 Replay).	No

UK

## 5.1 Find device and connect

With the function [Find device], connected devices are found or manually connected.

 The following ports must be open (if necessary, adapt the firewall settings):

- UDP: 3321
- TCP/HTTP: 80 and 8080
- TCP: 50010



Find a device:

- ▶ Connect the device to the voltage supply and to the PC via Ethernet.
- ▶ Click .
- > The ifm Vision Assistant searches for connected devices via Ethernet.
- > All devices found are shown in a selection list.
- ▶ Click on the button of the device found.
- > The device is connected.

 If the ifm Vision Assistant does not find a device automatically:

- Check if the device is correctly connected and ready for operation.
- The IP addresses of the device and the PC with the ifm Vision Assistant must be in the same subnet.
- Connect the device to the PC directly via Ethernet without network devices (e.g. router).
- Click [Manual connection] and enter the IP address manually (→ 5.1.1 Manual connection).

Messages after a device has been connected:

Message	Description
 <b>Sensor New sensor</b> 169.254.107.105 - O2I5XX	Displays information such as IP address and name of the device. Connects the device and continues depending on the application data (→ 5.2 Recently used).
 <b>No sensor found</b> If Windows is using DHCP, a device might only be found after waiting a few minutes.	If the IP address is retrieved automatically (via DHCP), it may take 1–2 minutes for the device to be connected and ready for operation.



With the key combination Ctrl+C, the text of a message is copied to the clipboard. This works with all messages displayed in the ifm Vision Assistant.

### 5.1.1 Manual connection

If automatic connection to the device is not possible, the connection is established manually.

Establish a connection manually:

- ▶ Click .
- ▶ Click [Manual connection].
- > The window "Manual connection" is displayed.
- ▶ Select "O2I5XX manual connection".
- ▶ Enter the IP address of the device (default: 192.168.0.69).
- ▶ Click [Connect].



- The IP addresses of the device and the PC with the ifm Vision Assistant must be in the same subnet.
- If the IP address is to remain unchanged as device address, the device must be rebooted after set-up (→ 10.1 General).

### 5.2 Recently used

The devices used last are displayed in a list. The devices are quickly connected again by clicking.

Connect the devices recently used:

- ▶ Click .
- > The devices recently used are displayed in the window "Recent".
- ▶ Establish Ethernet connection of the device to the PC or network.
- ▶ Click device in the list.
- > The ifm Vision Assistant establishes a connection to the device (→ 5.2 Recently used).

### 5.3 Options after connection

When the device was successfully connected, the ifm Vision Assistant continues with one of the following options:

State	Option
No application available	Application management opens (→ 8 Application management). A new device does not have any applications. The following actions delete all applications from the device: <ul style="list-style-type: none"> <li>• update firmware,</li> <li>• reset to factory settings,</li> <li>• manually delete all applications.</li> </ul> Applications are set in the chapter "Edit application" (→ 9 Edit application). Saved applications can be imported to the device (→ 8 Application management).
Active application available	Monitoring window opens (→ 7 Monitoring). If an application is available on the device and activated, the ifm Vision Assistant starts with the monitoring window (→ 7 Monitoring). To change parameters, the application is stopped.
Inactive application available	Application management opens (→ 8 Application management). If applications are available on the device but not activated, the ifm Vision Assistant starts with the application management (→ 8 Application management).
Error	Error message is displayed.







### 5.4 Replay

With this function, data that has been recorded can be viewed (→ 7 Monitoring). A connection to a device is not necessary.

Start replay:

- ▶ Click .
- ▶ Select file (\*.dat) and click [Open].
- > The screen for the replay is displayed.

The tab [Replay controls] contains the following operating elements:

Operating element	Name	Description
	Pause	Pauses the replay.
	Backward	Pauses the replay and displays the previous image.
	Foward	Pauses the replay and displays the next image.
	Start	Continues the replay.
	Progress bar	Indicates the current position of the replay. By clicking on the progress bar, the replay is continued at that position.
<b>Open other file</b>	Open other file	Opens a window in which a file for the replay can be selected.

Options in tab [View options]:

The "View options" are described in chapter (→ 7.2 View options).

Options in tab [Results]:

The results are described in the chapter (→ 7.3 Results).

Close replay:

▶ Click tab [Close].

> The screen for the replay closes.

## 5.5 Device status

The menu [Device status] displays information about the hardware and firmware of the connected device.

The [Device details] contain detailed information about the hardware and the firmware.

Save the information in a text file for diagnostics by the support people.

▶ Select menu [Device status].

▶ Click [Show device details].

> The device details are displayed.

▶ Click [Save].

> A file selection window is displayed.

▶ Click [Save].

> The device details are saved in a txt file.

## 5.6 Wiring

The menu [Wiring] contains information about wiring of the voltage supply of the device.

Display wiring:

▶ Select menu [Wiring].

▶ Select menu item [O2I].

> The wiring of the voltage supply of the device is displayed.

## 5.7 Settings

In the menu [Settings], the language of the user interface is set.

Set language:

▶ Select menu [Settings].

▶ Select list [language list].

▶ Select language.

> The language is set.

## 5.8 Help

The menu [Help] contains the following information:

- link to documentation as pdf file,
- contact details about the central manufacturer support,
- contact details about the local manufacturer support.

## 6 Structure of the user interface

The screen of the ifm Vision Assistant consists of the following areas:

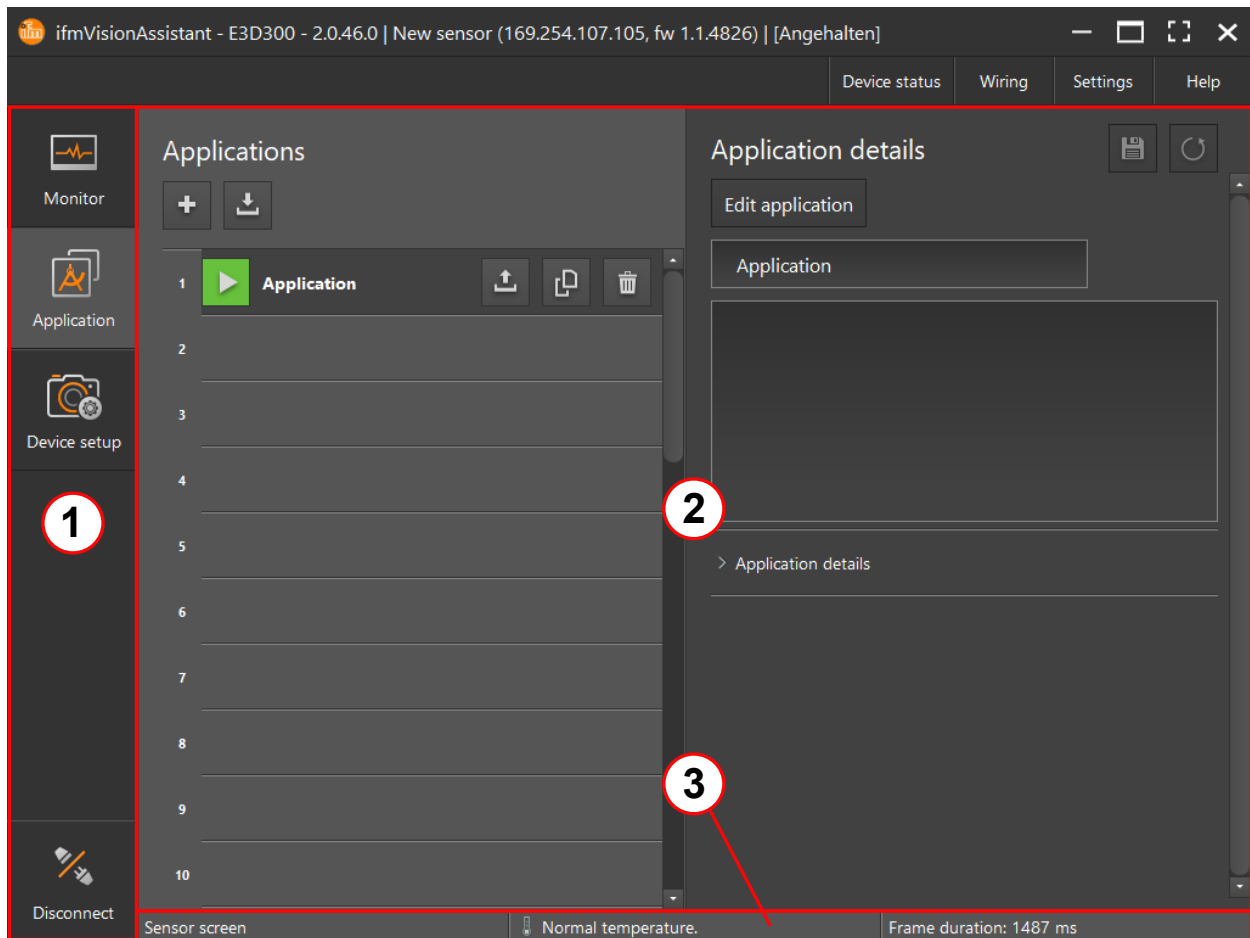





- ① Navigation bar: contains the functions (→ 6.1 Navigation bar).
- ② Main area: displays the contents of the selected function (→ 6.2 Main area).
- ③ Status bar: displays status information of the device (→ 6.3 Status bar).

UK

## 6.1 Navigation bar

The navigation bar contains the following operating elements:

Operating element	Name	Description
	Monitor	Opens the live image and displays the current device data (→ 7 Monitoring).
	Application	Opens an overview of the applications (→ 8 Application management). Manage and configure applications.
	Device configuration	Opens the device set-up (→ 10 Device set-up). For device settings that are independent of the applications.
	Disconnect	Disconnects the ifm Vision Assistant from the device. The ifm Vision Assistant returns to the start screen.

## 6.2 Main area

The main area displays the contents of the function selected in the navigation bar. The live image of the device is displayed in the main area (→ 9.2 Live image).

## 6.3 Status bar

The status bar shows the following information:

- Shows the window name which is currently open, e.g. "Monitoring" window.
- Temperature information about the device, e.g. "Normal temperature".
- Processing time of an image, e.g. "232 ms".



The processing time of an image is measured as follows:

from signal on the trigger input until the data is available at the process interface.



## 7 Monitoring

In monitoring, the active application is monitored. The device is in the operating mode.

After the connection of a device, monitoring is automatically displayed when an active application is available.

▶  Click .

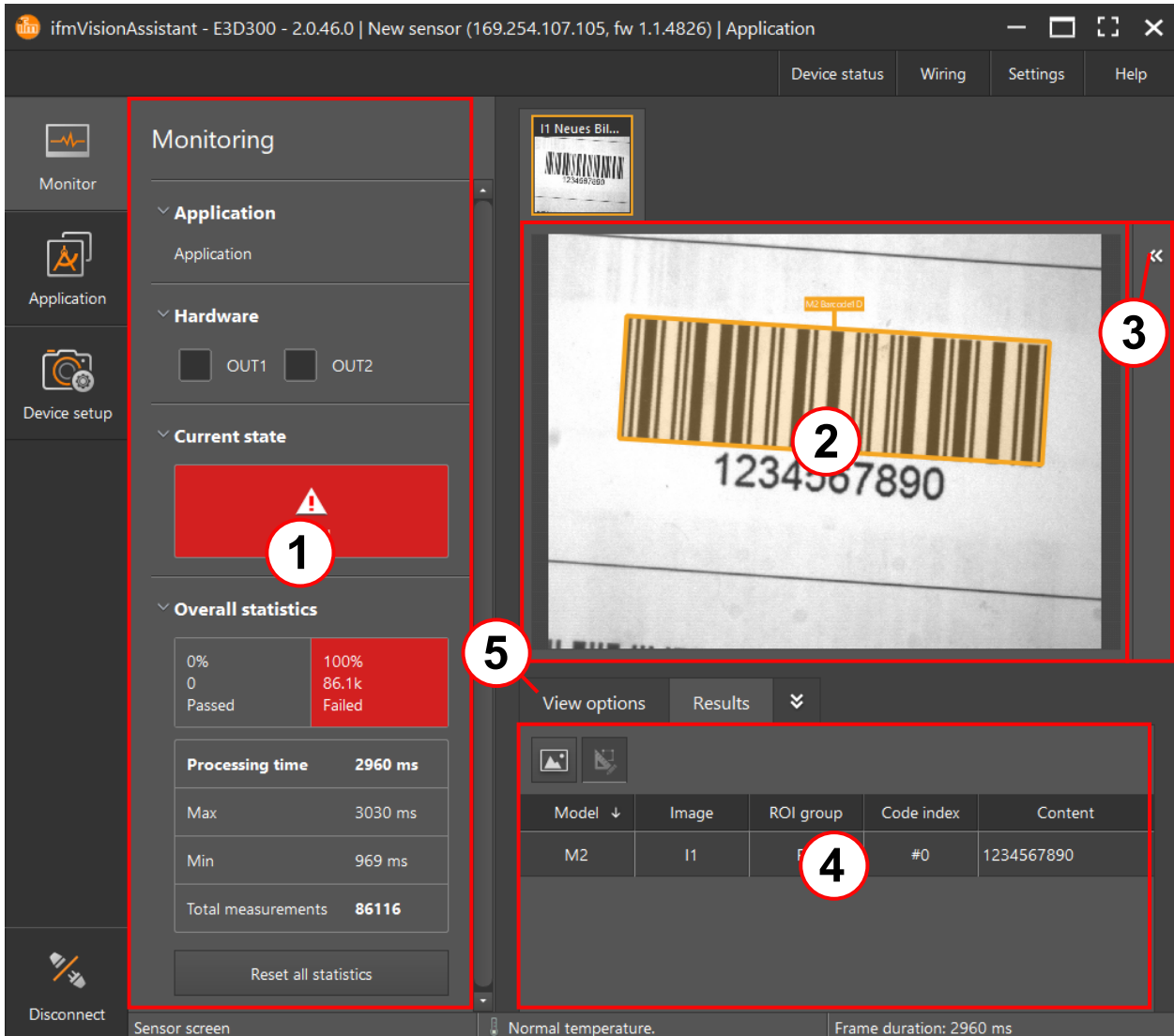

The screenshot shows the ifmVisionAssistant software interface. The title bar indicates the version (2.0.46.0) and sensor information. The interface is divided into a left sidebar with navigation icons (Monitor, Application, Device setup) and a main content area. The Monitoring screen displays application and hardware status, a live image of a barcode with a bounding box, and a results table. Red circles with numbers 1 through 5 highlight specific features:

- 1. Status indication (red bar with warning icon)
- 2. Live image (barcode with bounding box)
- 3. Code details (ROI group label)
- 4. Results (table with columns Model, Image, ROI group, Code index, Content)
- 5. View options (button above the results table)

Model	Image	ROI group	Code index	Content
M2	I1		#0	1234567890

- ① Status indication (→ 7.1 Status displays)
- ② Live image (→ 9.2 Live image)
- ③ Code details (→ 7.4 Code details)
- ④ Results (→ 7.3 Results)
- ⑤ View options (→ 7.2 View options)

### 7.1 Status displays

The status of the digital outputs and the statistics for the active application are displayed on the left of "Monitoring":

- Application: The name of the application is displayed.
- Hardware: The status LED (OUT1, OUT2) lights up yellow if there is a signal at the respective digital output.
- Current state: The current status of the application is displayed.

- Overall statistics
  - The statistically recorded values of all models of the active application are displayed. The values "Passed" and "Failed" are incremented via a counter. The ratio of the two values is indicated in per cent.
  - The evaluation time indicates the average, maximum and minimum time of the evaluation.
  - The button [Reset all statistics] resets the overall statistics.



The logic block "State definition: pass/fail" is necessary for counting the value "good/passed (green)" in the overall statistics (→ 9.6 Logic).

## 7.2 View options

"View options" contains options for adjusting the live image. The tab [View options] contains the following operating elements.

Operating element	Name	Description
	Zoom out	The view is zoomed out.
	Zoom reset	Resets the standard zoom level.
	Zoom in	The view is zoomed in.

## 7.3 Results

The "Results" display the models and images contained in an application and their characteristics in a list. The results can be restricted to the selected image or model. The tab [Results] contains the following operating elements.

Operating element	Name	Description
	Filter table by selected image	The characteristics of the selected image or model are displayed:
	Filter table by selected model	<ul style="list-style-type: none"> <li>• Model</li> <li>• Image</li> <li>• Roi group</li> <li>• Code index</li> <li>• Content</li> </ul>



The results can be copied to the clipboard:

- ▶ Press the key combination Ctrl+C.

## 7.4 Code details

The code details display details of the selected code.

To display the code details:

► Click .

> The code details are displayed to the right of the live image.

The code details contain the following information:

Code detail	Description
family	Family of the code
content	Content of the code
center column	Column of the code centre. The total number of columns corresponds to the x resolution of the device.
center row	Row of the code centre. The total number of rows corresponds to the y resolution of the device.
...	...
orientation	The rotation of the code in degrees with reference to the x axis.



The available code details depend on the selected code type.

Close the code details:

► Click .

> The code details are closed.







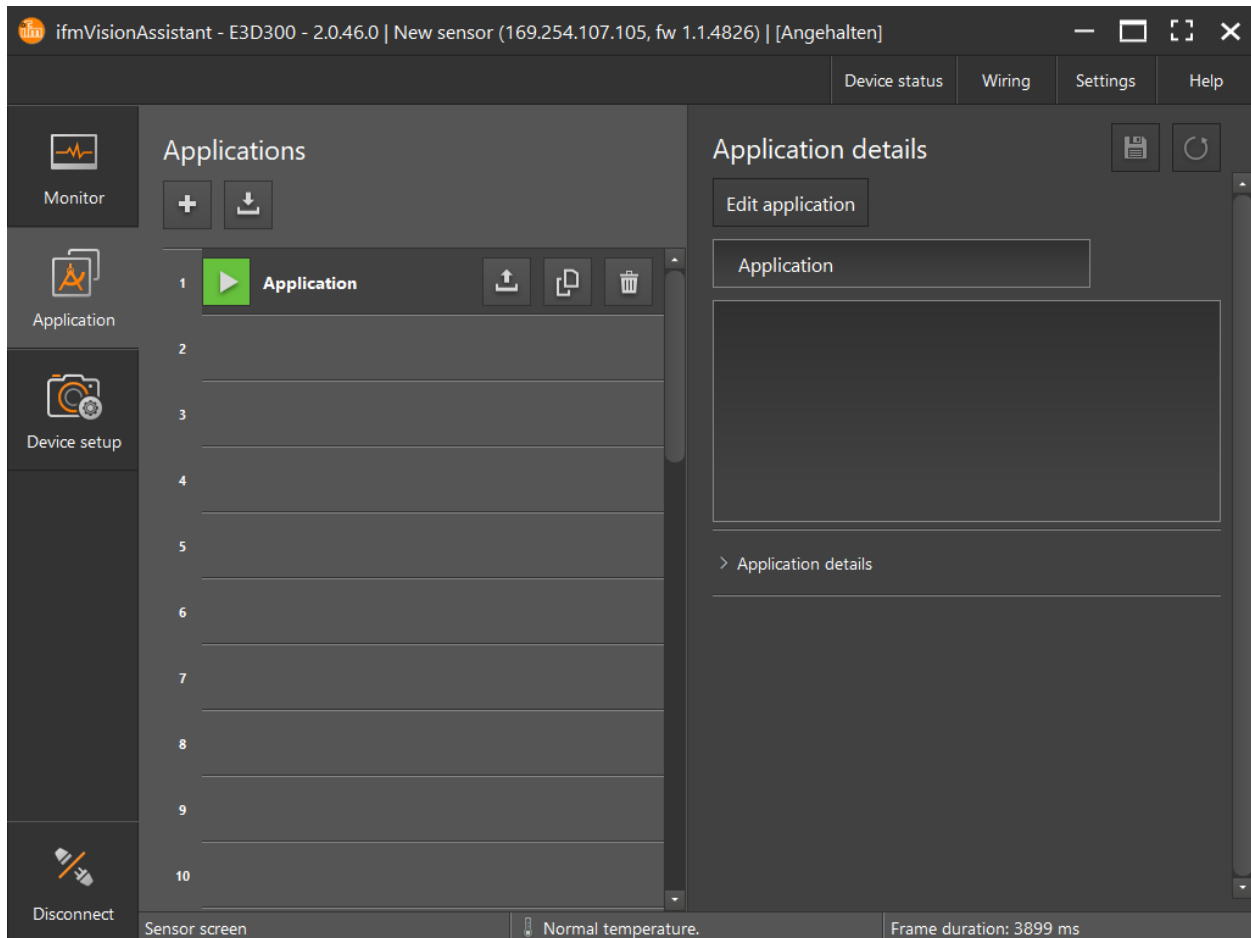

## 8 Application management





The application management manages the applications of the connected device. An application contains application-specific settings.



► Click .



The application management contains the following operating elements:

Operating element	Name	Description
	Add application	Creates a new application and starts the area "Edit application" (→ 9 Edit application).  The application management can manage maximum 32 applications.
	Import application	Imports an application from a file. A file selection window is displayed. The file has the extension "*.o2i5xxapp".  An error message is displayed if the file format of the imported application is not correct.
	Activate application	Activates the selected application. An active application is stopped. Only one application can be active at a time.  If several applications are available, the order of the applications can be changed by clicking and dragging using the mouse.
	Active application	Displays the active application.
	Export application	Exports the selected application to a file. A file selection window is displayed. The file has the extension "*.o2i5xxapp".

Operating element	Name	Description
	Duplicate application	Duplicates the selected application. An application is duplicated to test new parameters, for example.
	Delete application	Deletes the selected application. Deleting must be confirmed. An active application is deactivated during deletion.  Deleted applications cannot be restored.
	Save change	Saves the changes.
	Reject change	Rejects the changes and restores the original status.
<b>Application details</b>		
[Edit application]	Edit application	Changes to the area "Edit application". The selected application is edited in the area "Edit application" (→ 9 Edit application).
[Name]	Name of the application	Changes the name of the application.
[Description]	Description of the application	Changes the description of the application.

 The settings have to be saved:  
▶ Click .

UK

## 9 Edit application

The selected application is set in the area "Edit application".

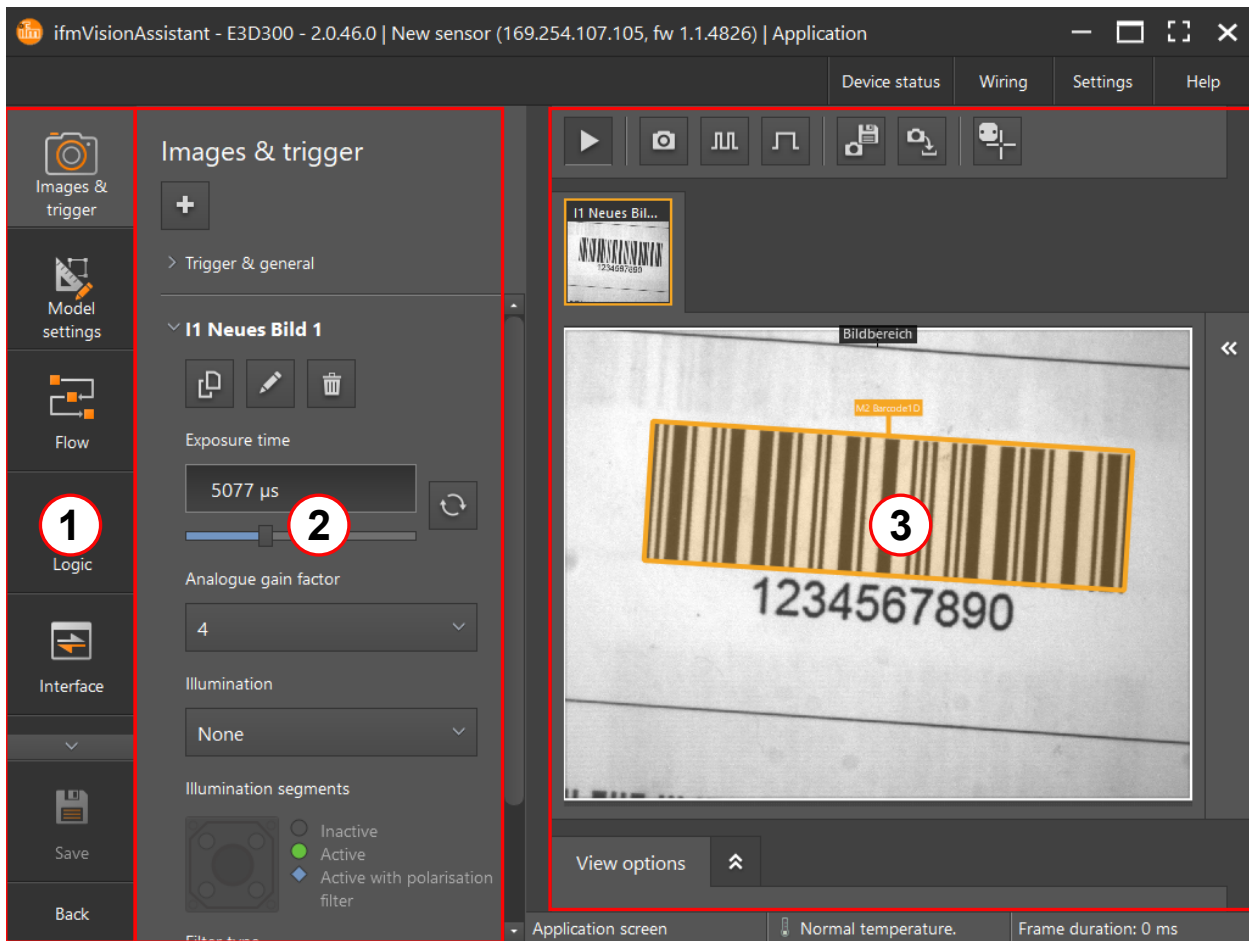

- ① Navigation bar: contains the functions (→ 6.1 Navigation bar).
- ② Settings: contains the settings of the selected function.
- ③ Main area: displays the contents of the selected function (→ 6.2 Main area). The live image of the device is displayed in the main area (→ 9.2 Live image).

### 9.1 Activate the area "Edit application"

The area "Edit application" is edited by

- adding a new application (→ 8 Application management),
- editing an existing application (→ 8 Application management).

## 9.2 Live image

The live image displays the current camera image of the device.

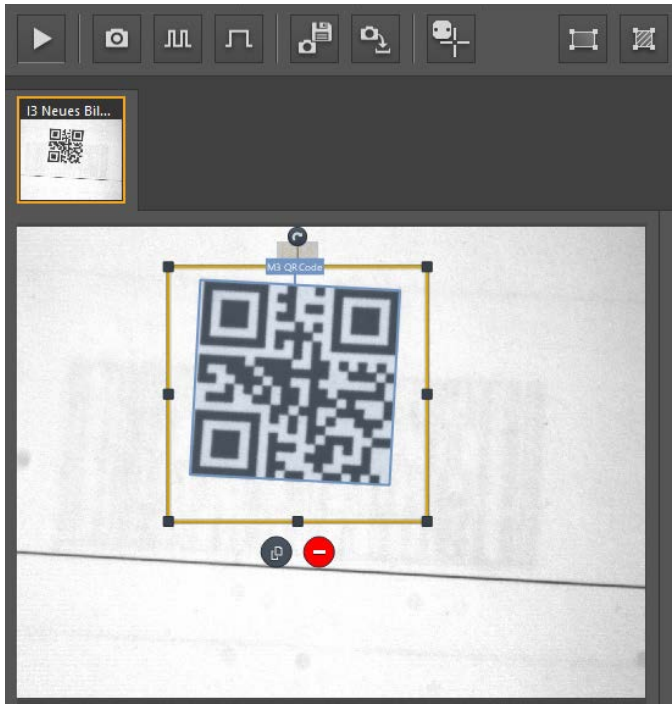













UK

The live image uses the following functions:

- images and trigger (→ 9.3 Images & trigger),
- model settings (→ 9.4 Model settings),
- flow (→ 9.5 Flow),
- test (→ 9.8 Test).

The live image contains the following operating elements:

Operating element	Name	Description
	Live image	Continuously refreshes the live image independently of the set trigger source and frame rate.
	Force trigger	Refreshes the live image once independently of the set trigger source.
	React to all triggers	Refreshes the live image on each trigger signal.
	Wait for a trigger	Refreshes the live image once on the next trigger signal.
	Save snapshot	Saves the current live image in a file. If several images exist, all are saved in a file. A file selection window is displayed. The file has the extension "*.o2i5xximg".
	Load snapshot	Loads the live image from a file. The loaded file is displayed instead of the live image. A file selection window is displayed. The file has the extension "*.o2i5xximg".   If a file contains several images, there may be an error message when the live image is loaded. ► Add the number of images in the ifm Vision Assistant before the live image is loaded (→ 9.3.4 Add new image).

Operating element	Name	Description
	Switch on/off laser adjustment aid	Activates the laser adjustment aid. The laser adjustment aids marks an area on the surface on which the code is placed for teaching by two red laser points (→ Operating instructions).
	Create rectangle ROI	Creates an ROI (region of interest). The device detects codes only within the ROI (→ 9.2.1 Create region of interest (ROI)).  The operating element [Create rectangular search zone (ROI)] is only visible in the model settings (→ 9.4 Model settings).
	Create rectangle ROD	Creates an ROD (Region of Disinterest). The device does not detect codes within the ROD (→ 9.2.2 Create region of disinterest (ROD)).  The operating element [Create rectangular region of disinterest (ROD)] is only visible in the model settings (→ 9.4 Model settings).

### 9.2.1 Create region of interest (ROI)

The device detects codes within the ROI (region of interest). When a model is added, an ROI covering the entire live image is automatically created.

 The operating element [Create rectangular search zone (ROI)] is only visible in the model settings (→ 9.4 Model settings).

 A total of up to 64 ROIs per model can be created.

Create an ROI:

- ▶ Select a model.
- > If there is none, a model has to be added (→ 9.4.1 Add new model).
- ▶ Click the live image  in the operating elements.
- > The mouse pointer turns into a cross hair.
- ▶ Create the ROI in the live image by clicking and dragging using the mouse.

Change the size and shape of an ROI:

- ▶ Select ROI.
- ▶ Click the corner points  of the ROI and drag it to the new position while pressing the mouse button.

Shift ROI:

- ▶ Select ROI.
- ▶ Drag ROI to the new position while pressing the mouse button.

Rotate ROI:

- ▶ Select ROI.
- ▶ Click  and rotate to the requested direction while pressing the mouse button.

Group ROIs:

- ▶ Select several ROIs while pressing the shift button.
- ▶ Click .



Copy ROI:

- ▶ Select ROI.
- ▶ Click .

Delete ROI:

- ▶ Select ROI.
- ▶ Click .

## 9.2.2 Create region of disinterest (ROD)

Codes within the ROD (region of disinterest) are ignored by the device.



The operating element [Create rectangular region of disinterest (ROD)] is only visible in the model settings (→ 9.4 Model settings).



A total of up to 64 RODs per model can be created.

Create an ROD:

- ▶ Select a model.
- > If there is none, a model has to be added (→ 9.4.1 Add new model).
- ▶ Click the live image  in the operating elements.
- > The mouse pointer turns into a cross hair.
- ▶ Create the ROD in the live image by clicking and dragging using the mouse.

Change the size and shape of an ROD:

- ▶ Select ROD.
- ▶ Click the corner points  of the ROD and drag it to the new position while pressing the mouse button.

Shift ROD:

- ▶ Select ROD.
- ▶ Drag ROD to the new position while pressing the mouse button.

Rotate ROD:

- ▶ Select ROD.
- ▶ Click  and rotate to the requested direction while pressing the mouse button.

Copy ROD:

- ▶ Select ROD.
- ▶ Click .

Delete ROD:

- ▶ Select ROD.
- ▶ Click .

### 9.3 Images & trigger

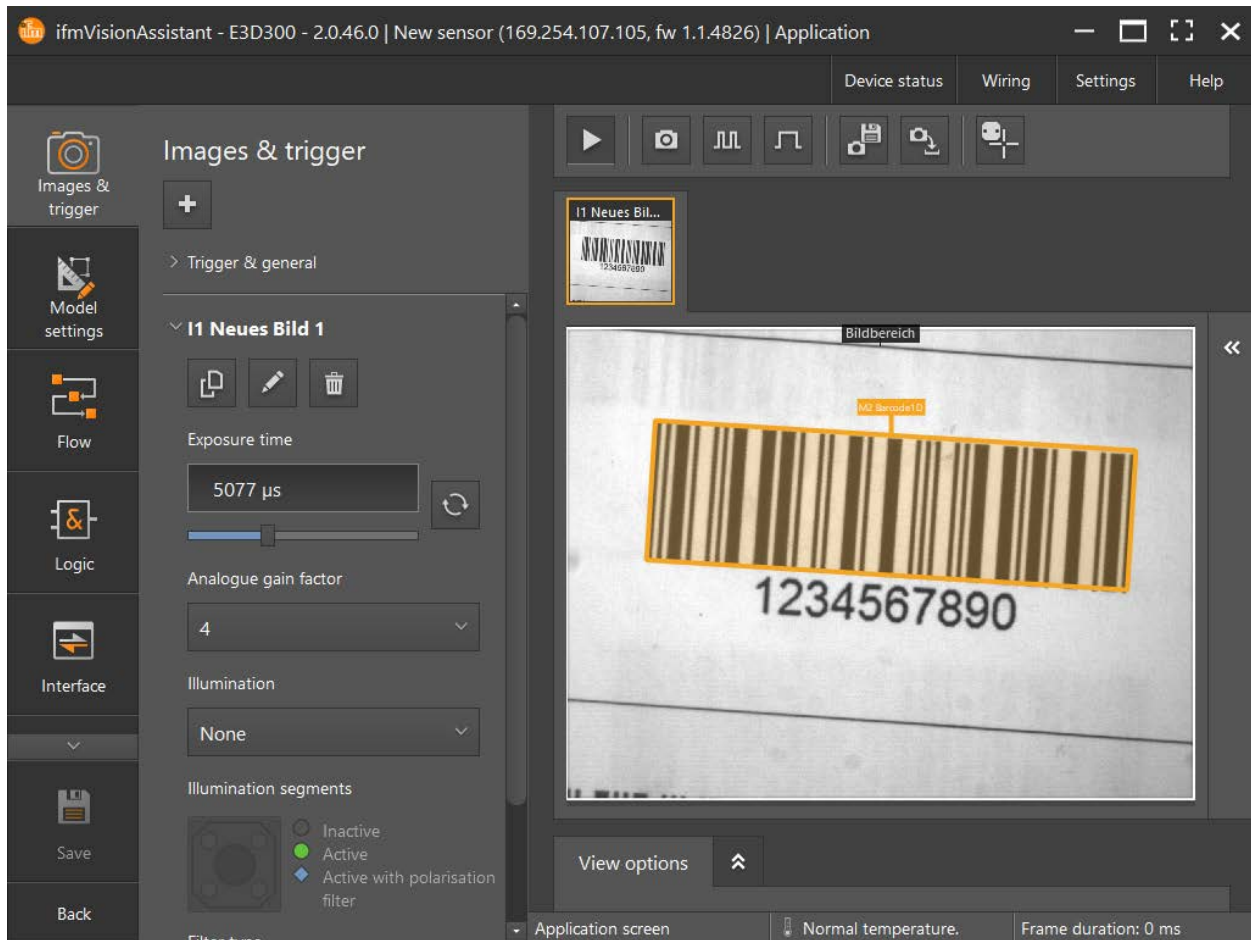

The function "Images & trigger" configures image and trigger settings of the selected application.

► Click .



 Many codes are detected in the standard setting, provided there are no models. To detect more codes, models have to be added (→ 9.4 Model settings).

The area "Trigger & general" contains the following operating elements:

Operating element	Name	Description
	Add new image	Adds a new image (→ 9.3.4 Add new image).
<b>Trigger &amp; general</b>		
[Trigger mode]	Trigger mode	Sets the trigger (→ 9.3.1 Trigger mode).
[Frame rate]	Frame rate	Sets the frame rate to be reached in fps (frames per second) (→ 9.3.2 Frame rate).
[Focus]	Focus	Sets the focus (→ 9.3.3 Focus).
	Optimise focus	Automatically optimises the focus (→ 9.3.3 Focus).
[Rotated by 180°]	Rotated by 180°	Rotates the live image by 180°.



### 9.3.1 Trigger mode

The list [Trigger mode] contains the following trigger modes:

Trigger mode	Description
[Continuous]	The device continuously captures images. This mode is usually used for tests.
[Process interface]	The device is triggered via the process interface (e.g. by a PLC).
[Positive edge]	The device is triggered via the rising edge of an input signal.
[Negative edge]	The device is triggered via the falling edge of an input signal.
[Both edges]	The device is triggered via the rising and falling edge of an input signal.
[Gated HW]	The device starts capturing images with a rising edge. As long as the trigger is on "High", images are captured with a fixed frame rate. The device stops capturing images on "Low".
[Gated PCIC]	The device starts capturing images with the g command of the process interface: 1234L000000008 1234g1 Images are captured with a fixed frame rate. The device stops capturing images with the following g command: 1234L000000008 1234g0

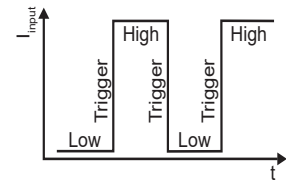
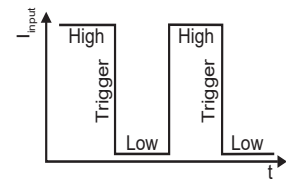
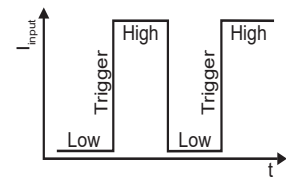

### 9.3.2 Frame rate

The input field [Frame rate] defines a maximum frame rate for the device.

Set the frame rate:

- ▶ Enter the frame rate in the input field [Frame rate] and confirm with [Enter].

 The frame rate only influences the trigger modes [Continuous] and [Process interface]. Depending on which settings are active, the requested frame rate will not be reached.

### 9.3.3 Focus

The input field [Focus] sets the distance in meters [m] between the lens and the code to be read. The optimum focus has been reached when the code in the live image is sharply displayed and is detected by the device.

 The set focus is used for all images. The focus cannot be set separately for each image.

Set the focus:

- ▶ Enter the distance in the input field [Focus] and confirm with [Enter].
- > The focus is additionally set with the slider bar. The minimum and maximum focus is displayed below the slider.

The focus is automatically optimised with the button  :

▶ Click .

> The focus is automatically optimised.



The value optimised via the automatic focus can be retrieved at any time:

▶ Click  in the input field [Focus].

> The value optimised via the automatic focus is displayed and can be selected.

### 9.3.4 Add new image







The following settings are saved in an image:

- exposure time
- analogue gain
- illumination
- filter

Up to 5 images with their own settings can be used in parallel. Several images ensure detection of codes with different

- qualities,
- surfaces,
- lighting conditions, etc.

The area "I1 New image 1" contains the following functions:

Operating element	Name	Description
<b>I1 New image 1</b>		
	Copy image	Copies the selected image and changes to the new image.
	Rename image	Renames the selected image.
	Delete image	Deletes the selected image.
[Exposure time]	Exposure time	Sets the exposure time (→ 9.3.5 Exposure time)
	Optimise exposure time	Automatically sets the exposure time (→ 9.3.5 Exposure time).
[Analogue gain factor]	Analogue gain factor	Sets the gain factor of the analogue signal (→ 9.3.6 Analogue gain factor).
[Illumination]	Illumination	Sets the internal and external illumination (→ 9.3.7 Illumination).
[Internal segments]	Illumination of internal segments	Displays the status of the internal illumination of the device.  With active internal illumination, individual segments are deactivated at one click.  The following devices have an additional polarisation filter: O2I500, O2I502 and O2I504.
[Filter type]	Filter type	Sets the filter for the image (→ 9.3.8 Filter type).
[Filter strength]	Filter strength	Sets the intensity of the selected filter type (→ 9.3.9 Filter strength).
[Invert filter]	Invert filter	Inverts the brightness values (→ 9.3.10 Invert filter).

### 9.3.5 Exposure time

The input field [Exposure time] sets the period in "µs" for the image capture.

Set the exposure time:

- ▶ Enter the exposure time in the input field [Exposure time] and confirm with [Enter].
- > The exposure time is additionally set with the slider bar.

The button [Optimise exposure time] automatically sets the exposure time:

- ▶ Click the button [Optimise exposure time].
- > The exposure time is automatically optimised.

### 9.3.6 Analogue gain factor

The list [Analogue gain factor] sets the gain factor of the analogue signal.

The analogue gain factor reacts linearly to the exposure time. Therefore, half of the exposure time can be used with double analogue gain factor. Especially dynamic applications benefit from the short exposure times.

Set the analogue gain factor:

- ▶ Select the factor in the list [Analogue gain factor].



The analogue gain factor increases the image noise.

### 9.3.7 Illumination

The list [Illumination] sets the illumination. The following illuminations are available:

Illumination	Description
[None]	The internal and external illuminations are deactivated.
[Internal]	<p>Activates the internal illumination of the device. In the section "Internal segments", the status of the internal illuminations is displayed. Individual segments are deactivated by clicking.</p> <p> The following devices have an additional polarisation filter: O2I500, O2I502 and O2I504.</p>
[External]	Activates the external illumination. The external illumination unit is connected to switching output OUT2 of the device. In addition, the external illumination has to be activated (→ 10.3 Interfaces). The illumination unit is active as long as switching output 2 is in the "high" state.
[Both]	Activates the internal and external illumination.

Set the illumination:

- ▶ Select the illumination in the list [Illumination].
- > The selected illumination is set.

### 9.3.8 Filter type

The list [Filter type] sets filters for the image with which the representation of the image is optimised. The following filters are available:

Filter type	Description
[Erosion]	Enlarges dark pixel groups and decreases light pixel gaps.
[Dilatation]	Enlarges light pixel groups and decreases dark pixel gaps.
[Median]	Reduces noise and noise pixels

Set the filter:

- ▶ Select the filter in the list [Filter type].
- > The selected filter is set.

### 9.3.9 Filter strength

The list [Filter strength] sets the intensity of the selected filter type. The following filter intensities are available:

Filter strength	Description
1 (weak)	Weak intensity of the selected filter type (preset).
2	
3	
4	
5 (strong)	Strong intensity of the selected filter type.

Set the filter intensity:

- ▶ Select the filter intensity in the list [Filter strength].
- > The selected filter intensity is set.

### 9.3.10 Invert filter

Inverts the brightness values of the selected image: black/white becomes white/black.



Inversion of the image is necessary with inverted 1D barcodes, e.g. for lasered metal surfaces.

## 9.4 Model settings



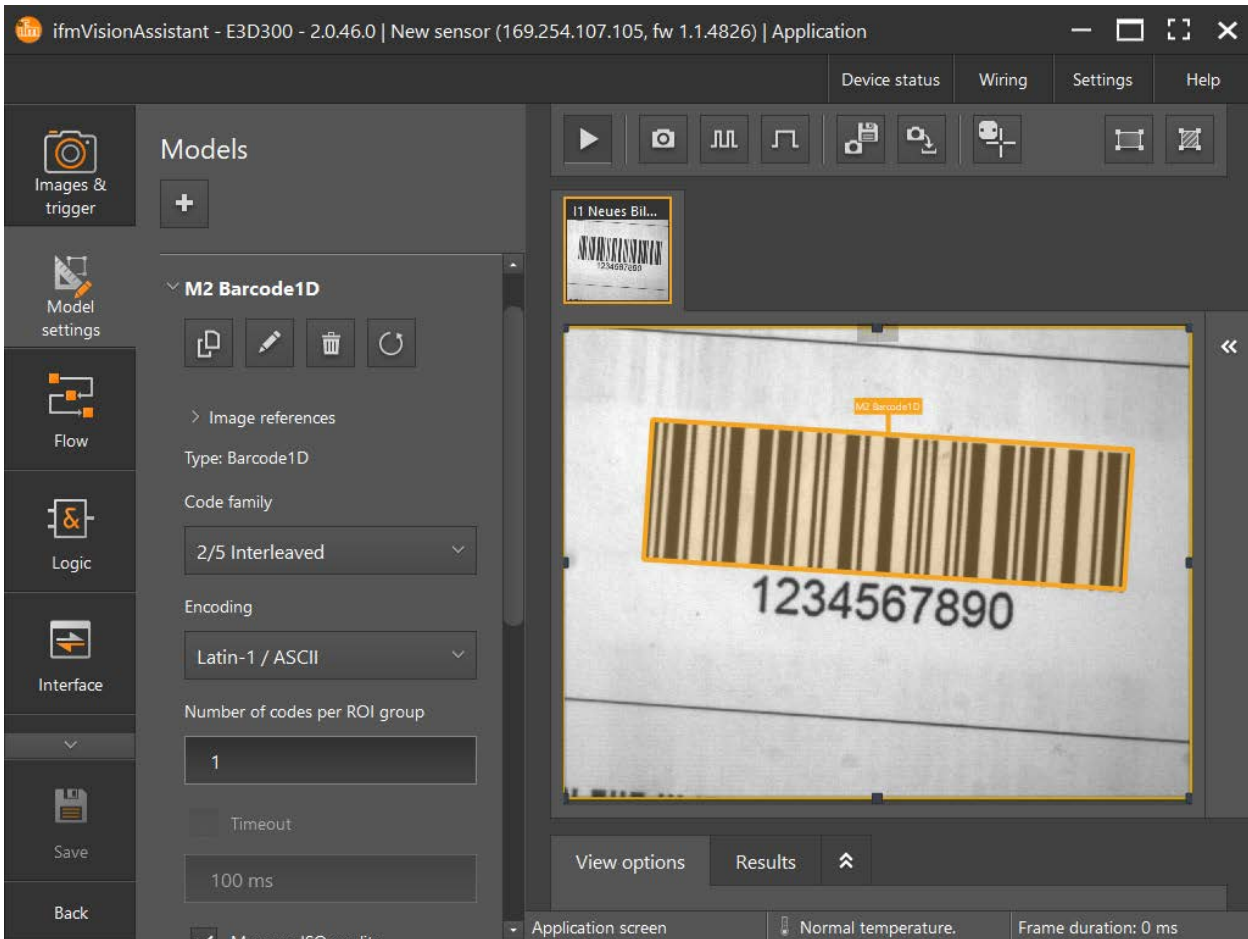

The function "Model settings" saves code types and their settings. One code type is saved per "model". Then the device searches for the saved code type. Should several code types be searched for, one model for each code type is added.

With the same search parameters, several codes of the same code type are saved in one model and saved in several models with different search parameters.

► Click 



The function "Model settings" contains the following operating elements:

Operating element	Name	Description
	Add new model	Adds a new model (→ 9.4.1 Add new model).
<b>M1 New model 1</b>		
	Copy model	Copies the selected model and changes to the new model.
	Rename model	Renames the selected model.
	Delete model	Deletes the selected model.
	Return to the default values	Resets all settings to the default settings.
<b>Apply model</b>		
[1 New image 1]	l1 New image 1	Applies the model to the selected image. Several images can be selected.



### 9.4.1 Add new model

A model has to be added to detect a certain code type. The code type and the associated settings are saved in the model.

 Up to 64 models can be created per application.

Add a new model:

► Click .

> A list with models is displayed:

Model	Description
Automatic code search	Starts the wizard "Create model". The wizard detects code types and creates a matching model.   The following code types are not detected by the wizard: <ul style="list-style-type: none"> <li>• PharmaCode</li> <li>• MSI</li> </ul>
1D barcode	Creates a model using a 1D barcode. Subsequently the code type must be selected (→ 9.4.2 Code types).
2D DataCode	Creates a model using a 2D DataCode. Subsequently the code type must be selected (→ 9.4.2 Code types).

► Select a model.

> The model was added.

### 9.4.2 Code types

The following code types are available:

Code family "1D barcode"	Code family "2D DataCode"
2/5 Industrial	Data Matrix ECC 200
2/5 Interlaced	QR code
Codabar	Micro QR Code
Code 128	PDF417
Code 39	Aztec code
Code 93	GS1 DataMatrix
EAN-13 Add-On 2	GS1 QR Code
EAN-13 Add-On 5	GS1 Aztec Code
EAN-13	
EAN-8 Add-On 2	
EAN-8 Add-On 5	
EAN-8	
GS1 DataBar Expanded Stacked	
GS1 DataBar Expanded	
GS1 DataBar Limited	
GS1 DataBar Omnidir	
GS1 DataBar Stacked Omnidir	
GS1 DataBar Stacked	
GS1 DataBar Truncated	
GS1-128	
MSI	
PharmaCode	
UPC-A Add-On 2	
UPC-A Add-On 5	
UPC-A	
UPC-E Add-On 2	



Code family "1D barcode"	Code family "2D DataCode"
UPC-E Add-On 5	
UPC-E	

### 9.4.3 Model with 1D barcode

A model with a "1D barcode" contains the following operating elements:

Operating element	Name	Description
[Type: 1D barcode]	Type: 1D barcode	Sets the code type (→ 9.4.2 Code types).
[Code family]	Code family	Shows the family of the code type.
[Encoding]	Encoding	Sets the character encoding (→ 9.4.4 Encoding).
[Number of codes per ROI group]	Number of codes per ROI group	Sets the number of the codes per ROI group (→ 9.4.5 Number of codes per ROI group).
[Timeout]	Timeout	Sets a timeout terminating the search for codes when the time has elapsed (→ 9.4.6 Timeout).
[Measure ISO quality]	Measure ISO quality	Sets the quality classification to ISO (→ 9.4.7 Measure ISO quality).
<b>Optimisation</b>		
[Contrast min]	Minimum contrast	Sets the minimum contrast between foreground and background (→ 9.4.8 Minimum contrast).
[Min. code length]	Minimum code length	Sets the minimum code length (→ 9.4.9 Min. code length).
[Quiet zone]	Quiet zone	Sets the verification of the quiet zones of a code (→ 9.4.10 Quiet zone).
<b>Advanced</b>		
[Orientation]	Orientation	Sets the orientation of the code (→ 9.4.11 Alignment).
[Orientation tolerance]	Orientation tolerance	Sets a zone for the function [Orientation] in which the code is detected (→ 9.4.12 Orientation tolerance).
[Num scanlines]	Number of scanlines	Sets the number of scanlines for the detection of a code (→ 9.4.13 Number of scanlines).
[Majority voting]	Majority voting	Sets the majority voting for the scanlines of single-line barcodes (→ 9.4.14 Majority voting).
[Merge scanlines]	Merge scanlines	Sets merging of scanlines of single-line barcodes (→ 9.4.15 Merge scanlines).
[Minimum identical scanlines]	Minimum identical scanlines	Sets the minimum number of successfully read scanlines (→ 9.4.16 Minimum identical scanlines).
[Start/Stop tolerance]	Start/Stop tolerance	Sets the tolerance for start and stop patterns (→ 9.4.17 Start/Stop tolerance).
[Element size variable]	Element size variable	Activates the compensation of the smallest element sizes of barcodes (→ 9.4.18 Element size variable).
<b>Size restriction</b>		
[Barcode height min]	Barcode height min	Sets the minimum barcode height (→ 9.4.19 Barcode height min).
[Barcode width min]	Barcode width min	Sets the minimum barcode width (→ 9.4.20 Barcode width min).

### 9.4.4 Encoding

The list [Encoding] sets the character encoding of the code contents. The following character encoding is available:

- Latin-1 / ASCII
- UTF-8

Set the character encoding:

- ▶ Select the character encoding in the list [Encoding].
- > The character encoding is set.

### 9.4.5 Number of codes per ROI group

The input field [Number of codes per ROI group] sets the maximum number of codes to be detected for an ROI group.



Grouping of ROIs is described in the following chapter:  
→ 9.2.1 Create region of interest (ROI).

Set the number of codes per ROI group:

- ▶ Enter the number of codes in the input field [Number of codes per ROI group].
- ▶ Confirm with [Enter].
- > The number of codes per ROI group is set.

Example of [Number of codes per ROI group] = "2":

- If 1 ROI exists: 2 codes are searched in this one ROI.
- If 2 ungrouped ROIs exist (each ROI counts as ROI group): 2 codes are searched in each ROI. Altogether, 4 codes are searched.
- If 2 grouped ROIs exist (1 ROI group): 2 codes are searched in this one ROI group. Altogether, 2 codes are searched. The codes may
  - both be contained in the first ROI,
  - both be contained in the second ROI,
  - 1 code each contained in each ROI.



A large number of codes to be detected increases the evaluation time of the device.

### 9.4.6 Timeout

The checkbox [Timeout] sets a timeout terminating the search for codes when the time has elapsed. The timeout ensures, for example, a maximum decoding time.

Set timeout:

- ▶ Activate checkbox [Timeout].
- ▶ Enter the time in milliseconds in the input field [Timeout].
- ▶ Confirm with [Enter].
- > The timeout is set.

### 9.4.7 Measure ISO quality

The checkbox [Measure ISO quality] evaluates the code quality of 1D code types. The evaluation of the code quality is available for the following 1D code types:

- 2/5 Interleaved, 2/5 Industrial
- Code 39, Code 93, Code 128
- EAN8, EAN8 Add-On 2, EAN8 Add-On 5
- EAN13, EAN13 Add-On 2, EAN13 Add-On 5
- UPC-A, UPC-A Add-On 2, UPC-A Add-On 5
- UPC-E, UPC-E Add-On 2, UPC-E Add-On 5
- GS1 Databar
- GS1-128
- MSI bar code
- Codabar
- Pharma code

The checkbox [Measure ISO quality] is suppressed for other code types.

Set the ISO quality parameters:

- ▶ Activate the checkbox [Measure ISO quality].
- > The selection field "Use-defined quality grade" is displayed. The contained quality parameters are deselected by clicking [X] and added by clicking [+].
- > The ISO quality parameters are set.



The function "Measure ISO quality" increases the evaluation time of the device.

The following quality parameters available:

Quality parameter	[Description]
Additional Requirements	Additional requirements
Decodability	Decodability
Decode	Decoding
Defects	Defects
Minimal Edge Contrast	Minimum edge contrast
Minimal Reflectance	Minimum reflectance
Modulation	Modulation
Symbol Contrast	Symbol contrast

More quality parameters are available for GS1 DataBar barcodes:

- ▶ Select a [GS1 data bar ...] in the list [Code family].
- ▶ Select the element [CC-A/B] in the list [Composite code].
- > The list [Quality parameters] is extended by the quality parameter [Composite ...].

The following quality parameters are available for GS1 DataBar barcodes:

Quality parameter [Composite ...]	[Description]
Codeword Yield	Codeword yield
Decodability	Decodability
Decode	Decoding
Defects	Defects
Modulation	Modulation
Unused Error Correction	Unused error correction

Quality parameter [Composite RAP ...]	[Description]
Contrast	Contrast
Decodability	Decodability
Defects	Defects
Minimal Edge Contrast	Minimum edge contrast
Minimal Reflectance	Minimum reflectance
Modulation	Modulation
Overall	Overall quality

### 9.4.8 Minimum contrast

The input field [Contrast min] sets the minimum contrast between foreground and background. If a code has a lower contrast, it is not detected.



A high value for [Contrast min] reduces the evaluation time of the device.

Set the minimum contrast:

- ▶ Enter the minimum contrast in the input field [Contrast min].
- > Preset: "0".
- ▶ Confirm with [Enter].
- > The minimum contrast is set.

### 9.4.9 Min. code length

The input field [Min code length] sets the minimum code length. If a code is of shorter code length, it is not detected.

Set the minimum code length:

- ▶ Enter the minimum code length in the input field [Min code length].
- > Preset: "0".



The value "3" is preset for the code types "2/5 Industrial" and "5/2 Interleaved". Code lengths "<3" lead to reading errors with these code types: The code types are erroneously detected in texts and samples .

- ▶ Confirm with [Enter].
- > The minimum code length is set.

### 9.4.10 Quiet zone

The list [Quiet zone] sets the verification of quiet zones of a code. The quiet zone is at least of the width of the narrowest bar of the barcode.

The following settings are available:

Quiet zone	Description
false	The codes are only detected if the quiet zones do not meet the specified minimum widths. With this setting, the device can detect small codes within a big code by mistake.
true	The codes are detected if the quiet zones meet the specified minimum widths. The following table contains the specified minimum widths as a multiple of a module width.
Tolerant	The codes are detected if a limited number of corners occur in the quiet zones. Maximum 1 corner per 4 module widths is allowed.
Custom	For the quiet zone [Custom], a factor is entered in the input field. The factor defines the minimum width of the quiet zones. With factor "1", codes are detected if the quiet zone is at least 1 x the width of the narrowest bar of the barcode. The following table contains the specified minimum widths as a multiple of a module width. Factor "2" requires double the minimum widths.

Set the quiet zone:

► Select the quiet zone in the list [Quiet zone].

> The quiet zone is set.

The code family "1D barcode " has the following quiet zones:

Code family "1D barcode"	Minimum width left quiet zone	Minimum width right quiet zone
2/5 Industrial	10	10
2/5 Interlaced	10	10
Codabar	10	10
Code 128	10	10
Code 39	10	10
Code 93	10	10
EAN-13 Add-On 2	7	5
EAN-13 Add-On 5	7	5
EAN-13	11	7
EAN-8 Add-On 2	7	5
EAN-8 Add-On 5	7	5
EAN-8	7	7
GS1 DataBar Expanded Stacked	1	1
GS1 DataBar Expanded	1	1
GS1 DataBar Limited	1	1
GS1 DataBar Omnidir	1	1
GS1 DataBar Stacked Omnidir	1	1
GS1 DataBar Stacked	1	1
GS1 DataBar Truncated	1	1
GS1-128	10	10
MSI	10	10
PharmaCode	5	5
UPC-A Add-On 2	9	5
UPC-A Add-On 5	9	5
UPC-A	9	9
UPC-E Add-On 2	9	5
UPC-E Add-On 5	9	5
UPC-E	9	7

### 9.4.11 Alignment

The input field [Orientation] sets the orientation of the code.

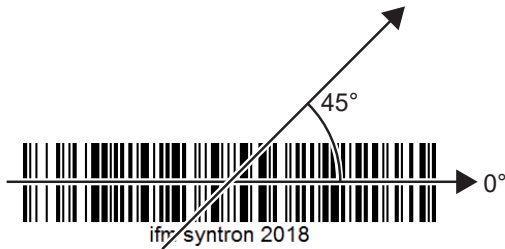

A code is detected if the average orientation of its bars corresponds to the value [orientation].

Set the orientation:

▶ Enter the orientation in the input field [Orientation].

> [0°] are preset. Value range: [-90...90°].



For "PharmaCode", the value range is: [-180...180°].

▶ Confirm with [Enter].

> The orientation is set.



The input field [Orientation tolerance] extends the individual value [Orientation] to a zone (→ 9.4.12 Orientation tolerance).

### 9.4.12 Orientation tolerance

The input field [Orientation tolerance] sets a tolerance for the function [Orientation]. The code is detected if the average orientation of its bars is in the range [Orientation tolerance].



The use of the function reduces the evaluation time of the device.

Set the orientation tolerance:

▶ Enter the orientation tolerance in the input field [Orientation tolerance].

> [90°] are preset. Value range: [0...90°].



With the maximum value [90°], all codes are detected, independently of the orientation.

▶ Confirm with [Enter].

> The orientation tolerance is set.

### 9.4.13 Number of scanlines

The input field [Num scanlines] sets the number of scanlines for detecting a code. The function reacts differently for single-row and stacked barcodes.

With a single-row barcode, scanning stops as soon as a barcode has been detected. A single-row barcode of poor quality requires more scanlines than a code of good quality. For a code of average quality, a value of "2...5" is sufficient. The value must be increased when the code is no longer detected.

With a stacked barcode, all scanlines are evaluated. A stacked barcode is composed of several rows (maximum 11 rows). The number of scanlines can be reduced if a low number of rows is expected.

With the preset value "0", a certain number of scanlines is used depending on the code type:

Code type	Number of scanlines
Single-row barcode: Code 128, EAN 13, GS1 DataBar Limited etc.	10
Stacked barcode: GS1 DataBar Stacked (Omnidirectional)	20
Stacked barcode: GS1 DataBar Expanded Stacked Stacked	55



If an image contains many incorrect code candidates, the evaluation time of the device is reduced with a small value of [Num scanlines].

Set the number of scanlines:

- ▶ Enter the number of scanlines in the input field [Num scanlines].
- > [0] is preset.
- ▶ Confirm with [Enter].
- > The number of scanlines is set.

#### 9.4.14 Majority voting

The checkbox [Majority voting] sets the majority voting for scanning single-row barcodes. The function reduces the number of incorrectly detected codes. If the function is activated, the result detected by the majority of all scanlines is used as overall result.



The use of the function increases the evaluation time of the device.



The function only affects single-row barcodes.

Set the majority voting:

- ▶ Activate the checkbox [Majority voting].
- > The default is "deactivated"
- > The majority voting is set.

#### 9.4.15 Merge scanlines

The checkbox [Merge scanlines] sets merging of scanlines in single-row barcodes. If no barcode was detected, scanlines are merged. A barcode is searched again in the merged scanlines which increases the chance of detection.



The use of the function increases the evaluation time of the device.



The function only affects single-row barcodes.

Set merging of scanlines:

- ▶ Activate the checkbox [Merge scanlines].
- > The default is "activated".
- > Merging of scanlines is set.



### 9.4.16 Minimum identical scanlines

The input field [Min identical scanlines] sets the minimum number of successfully detected scanlines. As soon as the minimum number is reached, the function forwards the result of the scan. The function reduces the probability of erroneously detecting barcodes.

The following applies with the value "0":

- The contents of a single-row barcode is already transferred with the first successful scanline.
- The contents of a multi-row barcode is transferred when each row of the barcode has been scanned successfully.

The table contains the preset values for different code types:

Code type	Preset value
2/5 Industrial	2
2/5 Interleaved	2
All other code types	0



If [Majority voting] is activated, the performance of [Min identical scanlines] changes (→ 9.4.14 Majority voting).



If [Merge scanlines] is activated, [Min identical scanlines] sets the number of scanlines with successfully detected edges (→ 9.4.15 Merge scanlines).

The "corners" refer to points in codes where the colour changes between white and black.

Set the minimum number of successfully read scanlines:

- ▶ Enter the minimum number of successfully read scanlines in the input field [Min identical scanlines].
  - ▶ Confirm with [Enter].
- > The minimum number of successfully read scanlines is set.

### 9.4.17 Start/Stop tolerance

The list [Start/Stop tolerance] sets the tolerance of the scanline for the start and stop patterns of codes.

The following [Start/Stop tolerance] settings are available:

Start/Stop tolerance	Description
High	A code is recognised with a higher probability. Poorly readable codes can be misrecognised.
Low	A code is recognised with a lower probability. Poorly readable codes are misrecognised less often.



The list [Start/Stop tolerance] is only available for code types [Code 128] and [GS1-128].

### 9.4.18 Element size variable

The checkbox [Element size variable] activates the compensation of the smallest element sizes. The smallest element sizes of a barcode can vary in size due to perspective-related distortions or distorted surfaces, making the barcode difficult to read. If the checkbox is activated, such distortions are balanced out where possible.



The checkbox [Element size variable] is only available for the following code types:

- [GS1 DataBar Expanded Stacked]
- [GS1 DataBar Expanded]
- [GS1 DataBar Limited]

### 9.4.19 Barcode height min

The list [Barcode height min] sets the minimum barcode height. The barcode height is automatically detected in the default setting. The manual setting improves setting of the barcode height for very flat and very high barcodes.



The use of the function reduces the evaluation time of the device.

The following settings for [Barcode height min] are available:

Barcode height min	Description
Automatic	The barcode height is set automatically.
Custom	The barcode height is set in pixels. Set the values manually for better detection. The smallest possible value is "8 pixels".

Set the minimum barcode height manually:

- ▶ Select the element "Custom" in the list [Barcode height min].
- ▶ Enter the minimum barcode height in the input field.
- > The smallest possible value is "8 pixels".
- ▶ Confirm with [Enter].
- > The minimum barcode height is set.

### 9.4.20 Barcode width min

The input field [Barcode width min] sets the minimum barcode width. If preset with the value "1", the barcode width is estimated by the device. Setting the barcode width improves the detection of barcodes.



The use of the function reduces the evaluation time of the device.

The minimum barcode width is set in pixels. The barcode width depends on the following factors:

- distance between device and barcode
- code type
- number of characters encoded in the barcode

Set the minimum barcode width:

- ▶ Enter the minimum barcode width in the input field [Barcode width min].
- ▶ Confirm with [Enter].
- > The minimum barcode width is set.

### 9.4.21 Model with 2D DataCode

A model with a "2D DataCode" contains the following operating elements:



The available operating elements depend on the set code type. The following operating elements are displayed with the code type "DataMatrix ECC 200".

Operating element	Name	Description
[Type: 2D Data-Code]	Type: 2D DataCode	Shows the family of the code type.
[Code family]	Code family	Sets the code type (→ 9.4.2 Code types).
[Presets]	Presets	Sets the presets (→ 9.4.22 Presets).
[Encoding]	Encoding	Sets the character encoding (→ 9.4.23 Encoding).
[Number of codes per ROI group]	Number of codes per ROI group	Sets the number of the codes per ROI group (→ 9.4.24 Number of codes per ROI group).
[Timeout]	Timeout	Sets a timeout terminating the search for codes when the time has elapsed (→ 9.4.25 Timeout).
[Quality grading]	Quality grading	Sets the quality grading (→ 9.4.26 Quality grading).
<b>Optimisation</b>		
[Polarity]	Polarity	Sets the polarity of the code to be detected (→ 9.4.27 Polarity).
[Strict quiet zone]	Strict quiet zone	Sets the performance in the event of a fault in the quiet zone of a code (→ 9.4.28 Strict quiet zone).
<b>Advanced</b>		
[Contrast tolerance]	Contrast tolerance	Sets the tolerance to contrast differences for finding codes (→ 9.4.29 Contrast tolerance).
[Finder pattern tolerance]	Finder pattern tolerance	Sets the performance in the event of errors in the finder pattern of the code (→ 9.4.30 Finder pattern tolerance).
[Module grid]	Module grid	Sets the calculation basis for the centre of a module (→ 9.4.31 Module grid).
[Max slant]	Max slant	Sets the maximum slant of the L-shaped finder pattern (→ 9.4.32 Max slant).
[Mirrored]	Mirrored	Sets the detection of mirrored codes (→ 9.4.33 Mirrored).
<b>Size restriction</b>		
[Symbol shape]	Symbol shape	Restricts the shape of the code which is to be detected (→ 9.4.34 Symbol shape).
[Symbol columns min]	Symbol columns min	Sets the minimum number of columns of the code which is to be detected (→ 9.4.35 Symbol columns min).
[Symbol columns max]	Symbol columns max	Sets the maximum number of columns of the code which is to be detected (→ 9.4.36 Symbol columns max).
[Symbol rows min]	Symbol rows min	Sets the minimum number of rows of the code which is to be detected (→ 9.4.37 Symbol rows min).
[Symbol rows max]	Symbol rows max	Sets the maximum number of rows of the code which is to be detected (→ 9.4.38 Symbol rows max).



### 9.4.22 Presets

The list [Presets] sets the model settings for a certain detection of codes. The following [Presets] are available:

Preset	Description
Standard detection	The fast detection of codes is set. Codes with a good contrast of a sufficient size are detected.
Enhanced detection	The reliable detection of codes is set. Inverted codes and codes with difficult contrast and size conditions are detected.
Maximum detection	The detection of codes with defects or hidden finder patterns is set. The probability to detect available codes is reduced.

Set the presets:

- ▶ Select preset in the list [Presets].
- > The selected preset is set.



The "Presets" are only visible if the code family "Datacode2D" has been selected.

### 9.4.23 Encoding

The list [Encoding] sets the character encoding of the code contents. The following character encoding is available:

- Latin-1 / ASCII
- UTF-8

Set the character encoding:

- ▶ Select the character encoding in the list [Encoding].
- > The character encoding is set.

### 9.4.24 Number of codes per ROI group

The input field [Number of codes per ROI group] sets the maximum number of codes to be detected for an ROI group.



Grouping of ROIs is described in the following chapter:

→ 9.2.1 Create region of interest (ROI).

Set the number of codes per ROI group:

- ▶ Enter the number of codes in the input field [Number of codes per ROI group].
- ▶ Confirm with [Enter].
- > The number of codes per ROI group is set.



A large number of codes to be detected increases the evaluation time of the device.

### 9.4.25 Timeout

The checkbox [Timeout] sets a timeout terminating the search for codes when the time has elapsed. The timeout ensures, for example, a maximum cycle time.

Set timeout:

- ▶ Activate checkbox [Timeout].
- ▶ Enter the time in milliseconds in the input field [Timeout].
- ▶ Confirm with [Enter].
- > The timeout is set.



### 9.4.26 Quality grading

The list [Quality grading] evaluates the code quality of 2D code types.

The following quality gradings are available:

Quality grading	Description												
ISO quality	<p>The grading of the quality following ISO/IEC 15415:2011 is set. A user-defined overall quality value can be set.</p> <p>The code quality is evaluated in 5 grades:</p> <table border="1"> <thead> <tr> <th>Code quality</th> <th>Description</th> </tr> </thead> <tbody> <tr> <td>4</td> <td>passed, very good, highest code quality</td> </tr> <tr> <td>3</td> <td>passed</td> </tr> <tr> <td>2</td> <td>passed</td> </tr> <tr> <td>1</td> <td>passed</td> </tr> <tr> <td>0</td> <td>not passed, lowest code quality</td> </tr> </tbody> </table>	Code quality	Description	4	passed, very good, highest code quality	3	passed	2	passed	1	passed	0	not passed, lowest code quality
Code quality	Description												
4	passed, very good, highest code quality												
3	passed												
2	passed												
1	passed												
0	not passed, lowest code quality												
AIM / ISO-TR29158 quality	The grading of the quality following AIM DPM-1-2006 is set. A user-defined value for the overall quality can be set.												
SEMI T10 quality	<p>The quality grading to SEMI T10 is set. The grading to SEMI T10 can be adapted.</p> <p> The quality grading "SEMI T10 quality" is only displayed with the code type "DataMatrix ECC 200".</p>												

Set quality grading:

- ▶ Select the quality grading in the list [Quality grading].
- > After the selection of the quality grading, the selection field "User-defined quality grade" is displayed. The contained quality parameters are deselected by clicking [X] and added by clicking [+].
- > The quality grading is set.

The following quality parameters are available for [ISO quality]:

Quality parameter	Data Matrix ECC 200	QR Code	Micro QR Code	PDF417	Aztec Code	GS1 Data Matrix	GS1 QR Code	GS1 Aztec Code	[Description]
Axial Nonuniformity	•	•	•	–	•	•	•	•	Ratio of the module size in horizontal and vertical direction.
Contrast	•	•	•	–	•	•	•	•	Contrast of the modules relative to the background.
Decode	•	•	•	–	•	•	•	•	Rating "4" if the code can be decoded, otherwise 0".
Fixed Pattern Damage	•	•	•	–	•	•	•	•	Error rate in the 3 basic elements of the code (finder pattern, alternating pattern and quiet zone).
Format Information	–	•	•	–	–	–	•	–	Contains information on error correction and the mask pattern.
Grid Nonuniformity	•	•	•	–	•	•	•	•	Orientation of the modules relative to the specific symbol grid.
Modulation	•	•	•	•	•	•	•	•	Uniformity of the light and dark modules.
Print Growth	•	•	•	–	•	•	•	•	Ratio dark/light modules in the alternating pattern.
Reflectance Margin	•	•	•	–	•	•	•	•	Assessment of the amplitude between the DataCode modules.

Quality parameter	Data Matrix ECC 200	QR Code	Micro QR Code	PDF417	Aztec Code	GS1 Data Matrix	GS1 QR Code	GS1 Aztec Code	[Description]
Unused Error Correction	•	•	•	•	•	•	•	•	Error of the code and share of the available error correction mechanisms to successfully decode the code.
Version Information	–	•	•	–	–	–	•	–	Contains information on the version of the QR code.
Codeword Yield	–	–	–	•	–	–	–	–	Assessment of the relative number of correctly decoded words.
Decodability	–	–	–	•	–	–	–	–	Assessment of the relative number of correctly decoded words.
Defects	–	–	–	•	–	–	–	–	Assessment of the bar/gap representation of the code.
Start/Stop Pattern	–	–	–	•	–	–	–	–	Assessment of the start and stop patterns.

"•": quality parameter available  
 "–": quality parameter not available

The following quality parameters are available for [AIM / ISO-TR29158 quality]:

Quality parameter	Data Matrix ECC 200	QR Code	Micro QR Code	PDF417	Aztec Code	GS1 Data Matrix	GS1 QR Code	GS1 Aztec Code	[Description]
Axial Nonuniformity	•	•	•	–	•	•	•	•	Ratio of the module size in horizontal and vertical direction.
Cell contrast	•	•	•	–	•	•	•	•	Contrast of the modules relative to the background.
Cell modulation	•	•	•	–	•	•	•	•	Uniformity of the light and dark modules.
Decode	•	•	•	–	•	•	•	•	Rating "4" if the code can be decoded, otherwise 0".
Fixed Pattern Damage	•	•	•	–	•	•	•	•	Error rate in the 3 basic elements of the code (finder pattern, alternating pattern and quiet zone).
Format Information	–	•	•	–	–	–	•	–	Contains information on error correction and the mask pattern.
Grid Nonuniformity	•	•	•	–	•	•	•	•	Orientation of the modules relative to the specific symbol grid.
Print Growth	•	•	•	–	•	•	•	•	Ratio dark/light modules in the alternating pattern.
Reflectance Margin	•	•	•	–	•	•	•	•	Assessment of the amplitude between the DataCode modules.
Unused Error Correction	•	•	•	–	•	•	•	•	Error of the code and share of the available error correction mechanisms to successfully decode the code.
Version Information	–	•	•	–	–	–	•	–	Contains information on the version of the QR code.

"•": quality parameter available  
 "–": quality parameter not available



The quality parameters are calculated on the basis of the selected quality grading. The following is required for the standard-compliant quality assessment of the image capture:

- a defined illumination and measurement geometry
- an adjustment of the image brightness by means of a calibrated code
- the definition of a measurement device suitable for the application.

### 9.4.27 Polarity

The list [Polarity] sets the polarity of the code to be detected. The following polarities are available:

Polarity	Description
Dark on light	Dark codes on light background are detected.
Light on dark	Light codes on dark background are detected.
Any	Dark codes on light and light codes on dark background are detected.

Set the polarity:

- ▶ Select polarity in the list [Polarity].
- > The polarity is set.

### 9.4.28 Strictly quiet zone

The checkbox [Strictly quiet zone] sets the performance in the event of a fault in the quiet zone of a code. The quiet zone is an empty zone framing a code. The quiet zone separates the code from other objects.

If the checkbox [Strictly quiet zone] is activated, codes with a damaged quiet zone are not detected. In addition, the erroneous detection of Micro QR Codes within text or QR codes is reduced.



The code type "Aztec Code" does not have a quiet zone.

Set the strictly quiet zone:

- ▶ Activate the checkbox [Strictly quiet zone].
- > The strictly quiet zone is set.

### 9.4.29 Contrast tolerance

The list [Contrast tolerance] sets the tolerance to contrast differences for code finding. Contrast differences are, for example, glare or reflections.



The contrast tolerance is only displayed with code type "DataMatrix ECC 200".

The following contrast tolerances are available:

Contrast tolerance	Description
Low	The tolerance of code finding with contrast differences is low. Under normal conditions, contrast differences are detected. This setting is suited for most applications. The setting has almost no influence on the evaluation time.
High	The tolerance of code finding with contrast differences is high. The setting has a significant influence on the evaluation time.
Any	The tolerance of code finding with contrast differences is selected by an algorithm.

Set the contrast tolerance:

- ▶ Select the contrast tolerance in the list [Contrast tolerance].
- > The contrast tolerance is set.

### 9.4.30 Finder pattern tolerance

The list [Finder pattern tolerance] sets the performance in the event of errors in the finder pattern of the code. The limiting lines framing the DataMatrix code are called finder pattern.



The finder pattern tolerance is only displayed with code type "DataMatrix ECC 200".

The following states are available:

Finder pattern tolerance	Description
Low	The code is detected if there is a high degree of finder pattern and there is almost no noise.
High	The code is detected if the finder pattern is defective or partly hidden. Only codes with a module grid of the same size are detected (→ 9.4.31 Module grid). Perspective distortions reduce the detection rate.
Any	The code is detected if <ul style="list-style-type: none"> <li>• there is a high degree of finder pattern and there is almost no noise or</li> <li>• the finder pattern is defective or partly hidden.</li> </ul>

Set finder pattern tolerance:

- ▶ Select the finder pattern tolerance in the list [Finder pattern tolerance].
- > The finder pattern tolerance is set.

### 9.4.31 Module grid

The list [Module grid] sets how the centre of a module is calculated. A DataMatrix code is composed of several modules.



The "Module grid" is preset to [Fixed] and cannot be changed if [Finder pattern tolerance] is set to [High].



The module grid is only displayed with code type "Data Matrix ECC 200".

The following module grids are available:

Module grid	Description
Fixed	The module grip has identical distances.
Variable	The module grid uses the alternating pattern opposite the finder pattern (L pattern) for orientation.
Any	The module grids [Fixed] and [Variable] are used one after the other.

Set the module grid:

- ▶ Select the module grid in the list [Module grid].
- > The module grid is set.

### 9.4.32 Max slant

The input field [Max slant] sets the maximum slant of the L-shaped finder pattern relative to a right angle. The angle is indicated in degrees and corresponds to the distortion occurring when the code is printed or an image is captured.



The maximum slant is only displayed with code type "DataMatrix ECC 200".

Set the maximum slant:

- ▶ Enter the maximum slant in the input field [Max slant].
- > [10°] are preset. Value range: [0...30°].
- ▶ Confirm with [Enter].
- > The maximum slant is set.

### 9.4.33 Mirrored

The list [Mirrored] sets the detection of mirrored codes. Codes are detected which are mirrored on the vertical or horizontal axis.



The following settings are available:

Mirrored	Description
No	Mirrored codes are not detected.
Yes	Only mirrored codes are detected.
Any	Mirrored and non-mirrored codes are detected.

Set mirrored:

- ▶ Select a setting in the list [Mirrored].
- > Mirrored is set.

### 9.4.34 Symbol shape

The list [Symbol shape] restricts the shape of the code to be detected.



If "Finder pattern tolerance" is set to [Low], the setting "Symbol shape" is ignored.

If "Finder pattern tolerance" is set to [High] or [Any], the "Symbol shape" [Rectangle] and [Square] considerably reduces the evaluation time.



The symbol shape is only displayed with code type "DataMatrix ECC 200".

The following symbol shapes are available:

Symbol shape	Description
Rectangle	Rectangular codes are detected.
Square	Square-shaped codes are detected.  With the symbol shape "Square", the number of rows and columns is set with the input fields [Symbol size min] and [Symbol size max].
Any	All codes are detected.

Set the symbol shape:

- ▶ Select the symbol shape in the list [Symbol shape].
- > The symbol shape is set.

### 9.4.35 Symbol columns min

The input field [Symbol columns min] sets the minimum number of columns to detect the code.

Depending on the "Symbol shape", the following values have to be used for [Symbol columns min]:

Symbol shape	Symbol columns min
Rectangle	>= 18
Any	>= 10

Set the minimum number of columns:

- ▶ Enter the minimum number of columns in the input field [Symbol columns min].
- ▶ Confirm with [Enter].
- > The minimum number of columns is set.

### 9.4.36 Symbol columns max

The input field [Symbol columns max] sets the maximum number of columns to detect the code.

Depending on the "Symbol shape", the following values have to be used for [Symbol columns max]:

Symbol shape	Symbol columns max
Rectangle	$\leq 48$
Any	$\leq 144$

Set the maximum number of columns:

- ▶ Enter the maximum number of columns in the input field [Symbol columns max].
- ▶ Confirm with [Enter].
- > The maximum number of columns is set.

### 9.4.37 Symbol rows min

The input field [Symbol rows min] sets the minimum number of rows to detect the code.

Depending on the "Symbol shape", the following values have to be used for [Symbol rows min]:

Symbol shape	Symbol rows min
Rectangle	$\geq 8$
Any	$\geq 8$

Set the minimum number of rows:

- ▶ Enter the minimum number of rows in the input field [Symbol rows min].
- ▶ Confirm with [Enter].
- > The minimum number of rows is set.

### 9.4.38 Symbol rows max

The input field [Symbol rows max] sets the maximum number of rows to detect the code.

Depending on the "Symbol shape", the following values have to be used for [Symbol rows max]:

Symbol shape	Symbol rows max
Rectangle	$\leq 16$
Any	$\leq 144$

Set the maximum number of rows:

- ▶ Enter the maximum number of rows in the input field [Symbol rows max].
- ▶ Confirm with [Enter].
- > The maximum number of rows is set.

### 9.4.39 Minimum symbol size

The input field [Symbol size min] sets the minimum number of symbol elements on the X/Y axis to detect a code.



The input field "Symbol size min" is only displayed when the symbol shape "Square" is set.

The following values have to be used for the symbol shape "Square".

Symbol shape	Symbol size min
Square	>= 10

Set the minimum number of symbol elements:

- ▶ Enter the minimum number of symbol elements in the input field [Symbol size min].
- ▶ Confirm with [Enter].
- > The minimum number of symbol elements is set.

### 9.4.40 Maximum symbol size

The input field [Symbol size max] sets the maximum number of symbol elements on the X/Y axis to detect a code.



The input field "symbol size max" is only displayed when the symbol shape "Square" is set.

The following values have to be used for the symbol shape "Square".

Symbol shape	Symbol size max
Square	<= 144

Set the maximum number of symbol elements:

- ▶ Enter the maximum number of symbol elements in the input field [Symbol size max].
- ▶ Confirm with [Enter].
- > The maximum number of symbol elements is set.

## 9.5 Flow

The function "Flow" displays the images and models available in a flow chart. In just a few steps

- the sequence in the evaluation of images and models is changed,
- images are deactivated and
- timeouts for models are set.

In addition, the required capture times of images and evaluation times of the models are displayed.

► Click .

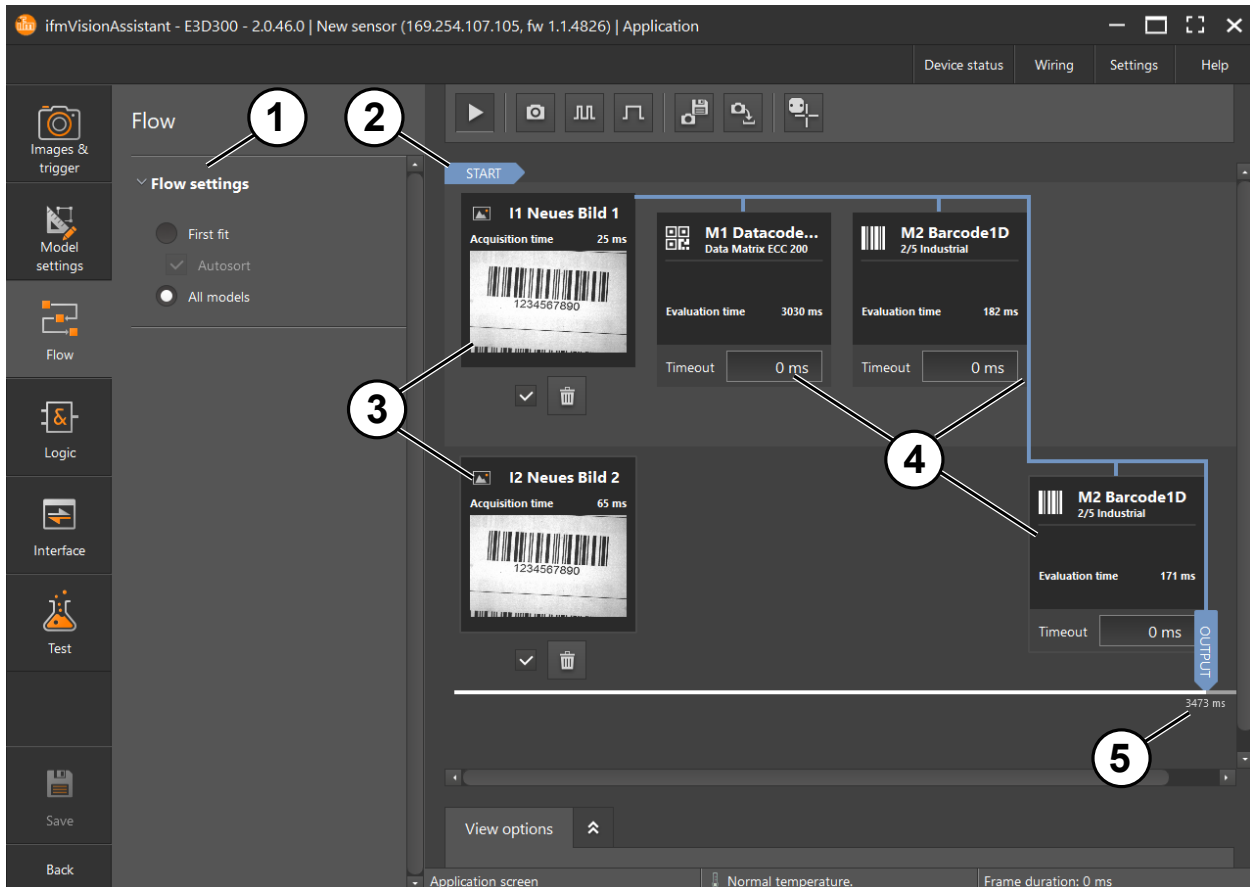

- ① Flow settings
- ② Start of the flow chart
- ③ Images
- ④ Models
- ⑤ End of the flow chart

### 9.5.1 Display flow chart

On the left side of the flow chart, images ③ are displayed (→ 9.3 Images & trigger). On the right side of the images, there are the corresponding models ④ (→ 9.4 Model settings).

The flow chart starts with the image underneath "START" ②. The active models ④ are connected with the blue line. Disabled models are greyed out and encircled with a dashed line.

The flow chart ends with "OUTPUT" ⑤. The total evaluation time is displayed underneath "OUTPUT". The total evaluation time is composed of the capture time of the image and the evaluation times of the models.



Double-clicking on an image or a model links directly to the respective settings.

The images ③ contain:

- image name
- current camera image
- capture time (corresponds to the exposure and image read-out time of the image)

The models ④ contain:

- model name
- code type
- status of the model (code detected)
- evaluation time (is influenced by the → 9.4 Model settings)
- timeout (→ 9.5.9 Set timeout for a model)

## 9.5.2 Set flow settings

With the flow settings ①, you set the sequence in which the images ③ and models ④ are executed.

The following settings are available:

- [First fit]  
The model which finishes the find task first in the flow chart and all previous models are executed. The models following in the flow chart are not executed.
- [Autosort]  
The model which detects a code first in the flow chart is executed. All other models are not executed.
- [All models]  
All models are executed. The total evaluation time increases.

## 9.5.3 Set the position of an image

The position of an image in the flow chart specifies when the image is executed (order in the evaluation).

Set the position of an image in the flow chart:

- ▶ Click the image and keep pressed.
- ▶ Drag the image to the new position upwards or downwards.

## 9.5.4 Activate or deactivate image

An image is activated or deactivated in the flow chart. A deactivated image is not considered in the flow chart. Models associated with the deactivated image are not considered, either.

Activate or deactivate an image:

- ▶ Activate or deactivate the checkbox (tick) underneath the image.

## 9.5.5 Delete image

An image can be deleted. The connection to the models is also deleted.



The image is deleted in all areas and not only in the flow chart (also in the area "Images & trigger"). The delete process cannot be reversed.

Delete an image:

- ▶ Click  underneath the image.
- ▶ Acknowledge the safety query.
- > The image is now deleted.

## 9.5.6 Set position of a model

The position of a model in the flow chart specifies when the image is executed (order in the evaluation).

Set the position of a model in the flow chart:

- ▶ Click the model and keep pressed.
- ▶ Drag the model to the new position to the left or to the right.

### 9.5.7 Connect model with image

Connect a model with an image:

- ▶ Click model.
- > The model is selected.
- ▶ Click  underneath the model.
- ▶ Activate or deactivate the checkbox of the image in the new window.
- ▶ Click [Save].
- > The model is connected to the image.



A model can be connected to several images.



The colours of the line encircling a model have different meanings:

- orange line: the model is marked
- no line: the model is not marked

In addition, the model is greyed out if it is not assigned to an image.

### 9.5.8 Delete model

A model can be deleted in the flow chart.



The model is deleted in all areas, i.e. also in the area "Model settings".

The delete process cannot be reversed.

Delete a model:

- ▶ Click model.
- > The model is selected.
- ▶ Click  underneath the model.
- ▶ Acknowledge the safety query.
- > The model is deleted.

### 9.5.9 Set timeout for a model

A timeout can be set for a model. If the evaluation time of the model exceeds the timeout, the evaluation is stopped.

Set timeout for a model:

- ▶ Enter the time in milliseconds in the input field [Timeout].
- ▶ Confirm with [Enter].
- > The timeout is set.

## 9.6 Logic

The function "Logic" contains logic blocks with which an output logic is created (→ 9.6.4 Create output logic). The model and pin events are assigned to the outputs in the output logic. Then the data can be transferred to a controller (PLC/PC).

► Click .

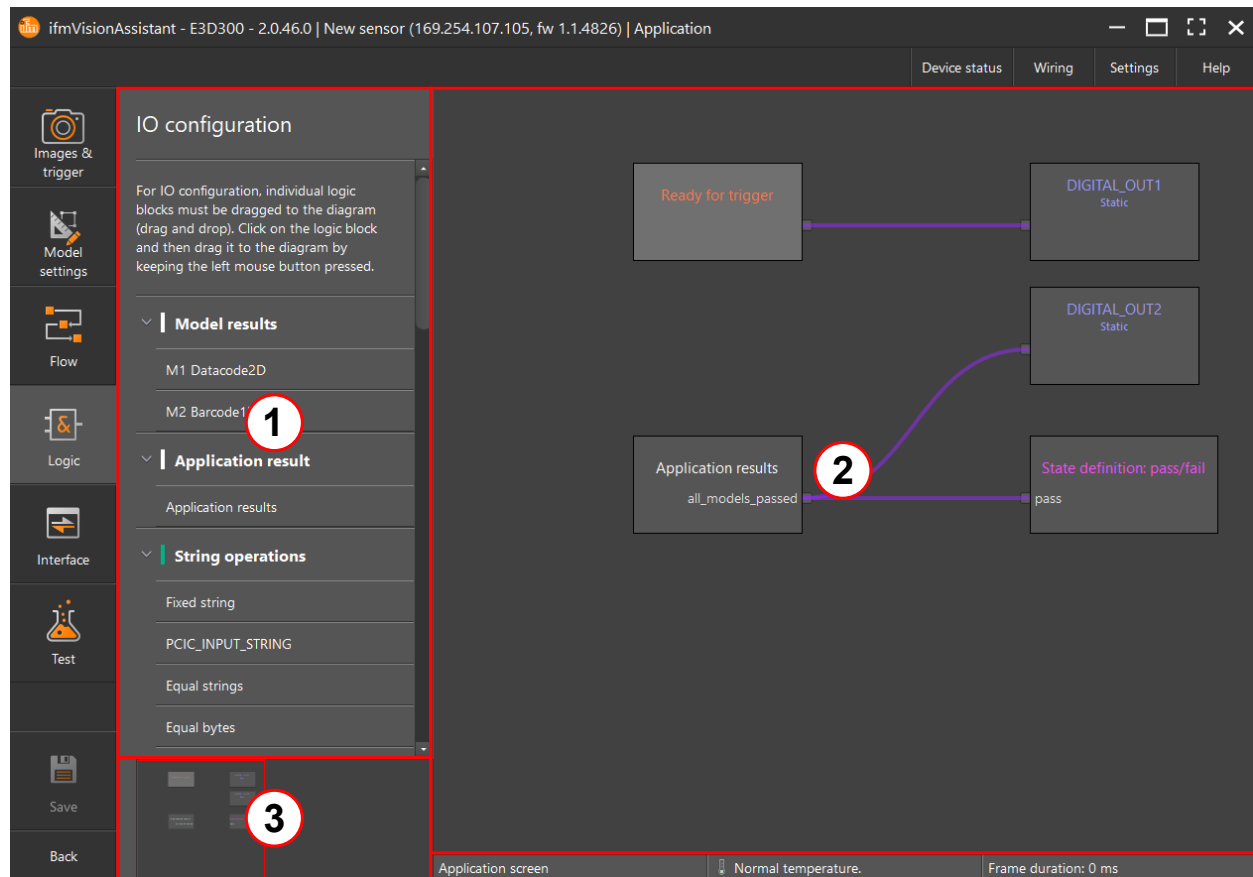

- ① Logic blocks (→ 9.6.1 Logic blocks)
- ② Main area (→ 9.6.2 Main area)
- ③ Overview area (→ 9.6.3 Overview area)

### 9.6.1 Logic blocks

The logic blocks contain the modules with which the model and pin events are assigned to the outputs. The logic blocks are placed in the main area using drag and drop (→ 9.6.5 Place logic block in the main area).

### 9.6.2 Main area

The output logic is created in the main area. The pin events and the outputs are displayed as logic modules with different font colours. The logic blocks are connected by connecting lines.

### 9.6.3 Overview area

The overview area displays a reduced overview of the main area. The red frame is shifted using the mouse. Therefore, the logic blocks outside the current main area can be displayed.

### 9.6.4 Create output logic

The model and pin events are assigned to the outputs in the output logic. The following rules apply for creating an output logic:

- The pin events are provided as boolean numbers (1 = true, 0 = false) and assigned to digital outputs.
- The model results are numerical values and are processed as follows:
  - use of operators
  - digitalisation by comparison with other results or values
  - transfer of digitalised numerical values by applying arithmetic operators and/or logic functions
  - output of a boolean value via a digital output or a virtual pin

The following figure shows an overview of the configuration options in the output logic. The numbers identify the connection between the logic blocks.

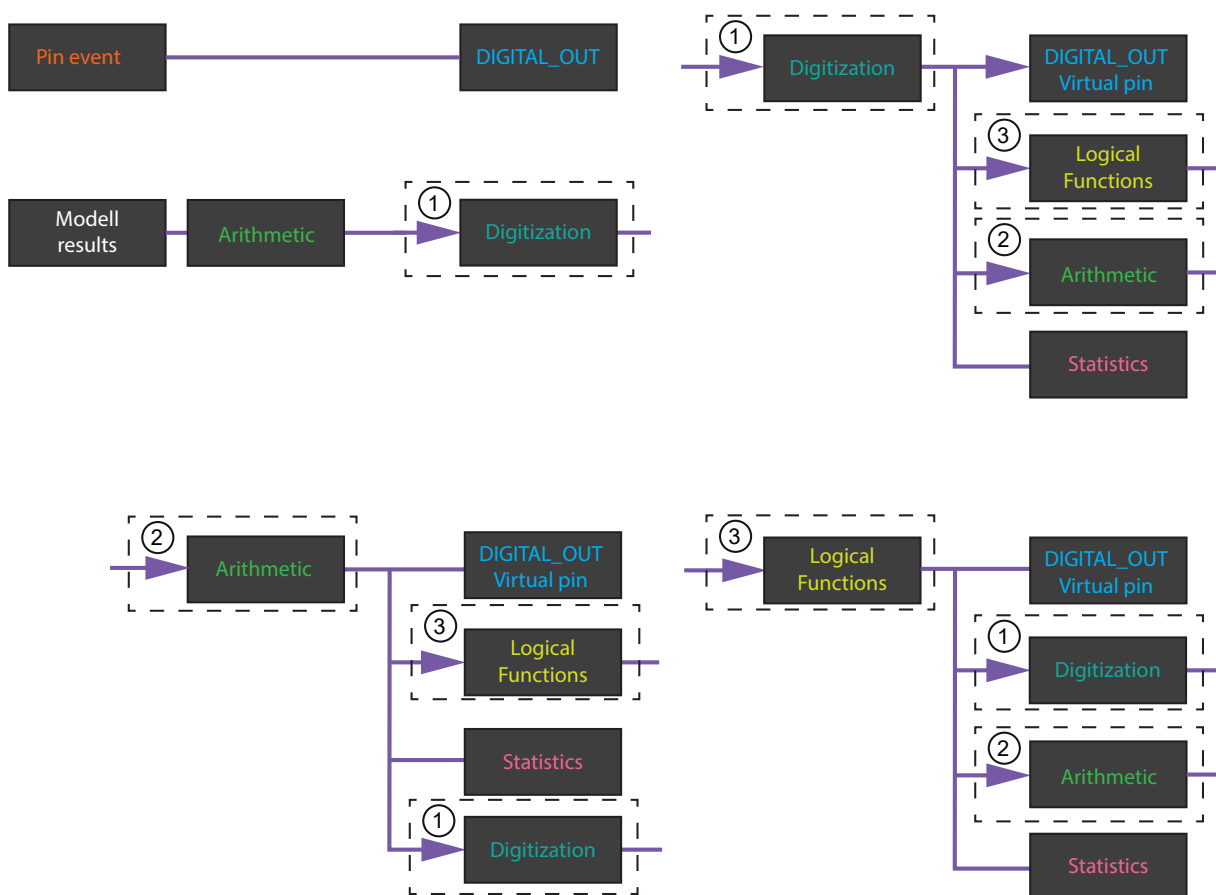

### 9.6.5 Place logic block in the main area

The logic blocks are placed in the main area by means of drag and drop:

- ▶ Click the logic block and keep the mouse button pressed.
- ▶ Drag the logic block into the main area and release the mouse button.
- > The logic block is placed. The logic block is subsequently shifted by means of drag and drop.

At the edge of each logic block, there is at least one contact area via which the logic blocks are connected (→ 9.6.8 Connect logic block)



## 9.6.6 Set logic block

A logic block can be set if it has been selected and is displayed underneath the symbol .

Set a logic block:

- ▶ Click the logic block.
- ▶ Click .
- > The settings are displayed in a window.

## 9.6.7 Delete logic block

Delete a logic block:

- ▶ Click the logic block.
- ▶ Click .
- > The logic block is deleted. The connecting lines to other logic blocks are also deleted.

## 9.6.8 Connect logic block

The logic blocks are connected by connecting lines via the contact areas at the border.

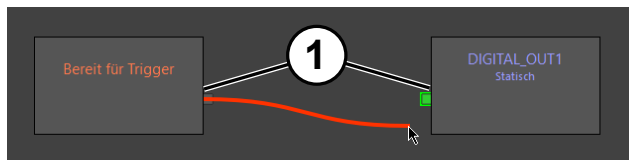

### ① Contact areas

Connect a logic block:

- ▶ Click the contact area at the right border of a logic block and keep the mouse button pressed.
- > The contact areas of the outputs are at the right border. An output contact area is connected with one or several connecting lines.
- ▶ Drag the connecting line to a free contact area on the left border of a logic block and release the mouse button.
- > The contact areas of the inputs are at the left border. Free contact areas are coloured in green. An input contact area is connected with only one connecting line.



During connection, the compatibility of the logic block is verified. Numeric and boolean values cannot be connected, for example.

During connection, the units of measurement of the logic blocks are not verified.

## 9.6.9 Delete connecting lines

Delete a connecting line between 2 logic blocks:

- ▶ Click the connecting line.
- ▶ Click .
- > The connecting line is deleted.

### 9.6.10 Description of the logic blocks "Model results"

The area "Model results" contains the models saved in the "Model settings" as logic blocks. The logic blocks provide different characteristics of the detected codes.

When a logic block has been placed in the main area, the following window appears:

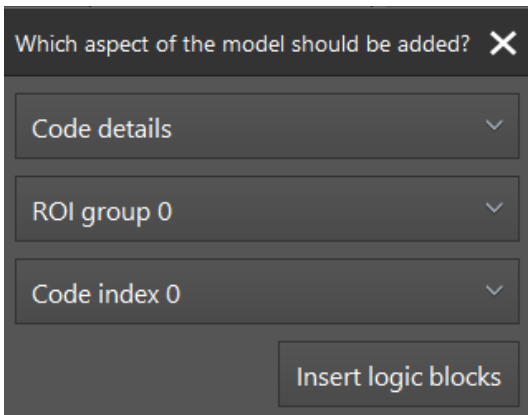

The window consists of 3 lists. In the first list, the function of the logic block is set:

#### Function [Code details]

Function [Code details]: The status of a certain code is provided. The logic block has the following settings:

Function "Code details"	Description
[Code details]	The status of a certain code is provided.
[ROI group 0]	The ROI group is selected.
[Code index 0]	The code is selected. To access a certain code, the number of codes per ROI group must be set to a value ">=0" (→ 9.4.24 Number of codes per ROI group).

The logic block [Code details] has the following outputs:

Outputs "Code detail"	Number format	Description
Code content	alphanumeric	The code content is provided taking into account the encoding (→ 9.4.23 Encoding).
Code found	bool	The status "Code found" or "Code not found" is provided.
centerX	numerical	The centre of the code on the X axis is provided.
centerY	numerical	The centre of the code on the Y axis is provided.
Orientation	numerical	The orientation of the code is provided in degrees.
half height	numerical	Half the height of the code is provided.
half width	numerical	Half the width of the code is provided.
Code content raw	byte array	The code content is provided as uncoded raw data (byte array). The output is connected with the logic block "Equal bytes" (→ 9.6.12 Description of the logic blocks "String operations").

## Function [Quality grading]

Function [Quality grading]: The code grading is assessed by 1D or 2D code types.



The function [Quality grading] can be selected for 1D code types if the checkbox [Measure ISO quality] is active in the associated model (→ 9.4.7 Measure ISO quality).

The function [Quality grading] can be selected for 2D code types if a block has been selected from the list [Quality grading] in the associated model (→ 9.4.26 Quality grading).

The code quality of the code types is assessed. The logic block has the following settings:

Function "Quality grading"	Description
[Quality grading]	The code quality of the code types is assessed.
[ROI group 0]	The ROI group is selected.
[Code index 0]	The code is selected. To access a certain code, the number of codes per ROI group must be set to a value ">=0" (→ 9.4.24 Number of codes per ROI group).

UK

## 1D code types

The logic block [Quality grading] has the following outputs for 1D code types:

Outputs "Quality grading"	Number format	Description
User-defined overall	Float	Overall quality of the code corresponds to the individual characteristic with the poorest effect. Depends on the set quality parameters.
Overall quality	Float	Overall quality of the code corresponds to the individual characteristic with the poorest effect. The following quality gradings exist: <ul style="list-style-type: none"> <li>• 0-4 (0 = bad; 4 = very good)</li> <li>• A-F (F = bad; A = very good)</li> </ul> The grading 0-4 or A-F is determined by the standard used.
Additional requirements	Float	Specific requirements of the symbology
Decodability	Float	Deviations of the symbol element widths from the nominal value. The nominal value is defined in the symbology standard.
Decode	Float	Readability of the examined barcode symbol: "4": barcode symbol can be read "0": barcode symbol cannot be read
Defects	Float	Defects are irregularities in the grey-scale value profile of symbol elements or quiet zones.
Minimum edge contrast	Float	Assessment of the minimum contrast between two adjoining symbol elements in the grey-scale value profile (light to dark element or dark to light element).
Minimum reflectance	Float	Minimum reflection value of the grey-scale value profile: "4": the minimum reflection value is <= 0.5 of the maximum reflection value "0": the minimum reflection value is <= 0.5 of the maximum reflection value
Modulation	Float	Uniformity of the light and dark bars.
Symbol contrast	Float	Contrast of the bars against the background.

## 2D code types

The logic block [Quality grading] has the following outputs for 2D code types and the quality grading [ISO]:

Outputs "Quality grading"	Number format	Description
User-defined overall	Float	Overall quality of the code corresponds to the individual characteristic with the poorest effect. Depends on the set quality parameters.
Overall quality	Float	Overall quality of the code corresponds to the individual characteristic with the poorest effect. The following quality gradings exist: <ul style="list-style-type: none"> <li>• 0-4 (0 = bad; 4 = very good)</li> <li>• A-F (F = bad; A = very good)</li> </ul> The grading 0-4 or A-F is determined by the standard used.
Contrast	Float	Contrast of the modules relative to the background.
Modulation	Float	Uniformity of the light and dark modules.
Fixed Pattern Damage	Float	Error rate in the 3 basic elements of the code: finder pattern, alternating pattern and quiet zone.
Decode	Float	Rating 4 if the code can be decoded, otherwise 0.
Axial nonuniformity	Float	Ratio of the module size in horizontal and vertical direction.
Grid nonuniformity	Float	Orientation of the modules relative to the specific symbol grid.
Unused error correction	Float	Error of the code and share of the available error correction mechanisms to successfully decode the code.
Reflectance margin	Float	Assessment of the amplitude between the DataCode modules.
Print growth	Float	Ratio dark/light modules in the alternating pattern.
Contrast uniformity	Float	Smallest numerical value for the modulation in the entire code.
Aperture	Float	Size indication of the synthetic aperture in relation to the module size of the symbol. The aperture is used to create the reference grey-scale image which is required for the quality assessment.
Format information (mqr/qr only)	Float	Assessment of the modules containing the format information.
Version information (mqr/qr only)	Float	Assessment of the modules containing the version information.

The logic block [Quality grading] has the following outputs for 2D code types and the quality standard [AIM]:

Outputs "Quality grading"	Number format	Description
User-defined overall	Float	Overall quality of the code corresponds to the individual characteristic with the poorest effect. Depends on the set quality parameters.
Overall quality	Float	Overall quality of the code corresponds to the individual characteristic with the poorest effect.
Cell contrast	Float	Contrast of the modules relative to the background.
Cell modulation	Float	Uniformity of the light and dark modules.
Fixed Pattern Damage	Float	Error rate in the 3 basic elements of the code: finder pattern, alternating pattern and quiet zone.
Decode	Float	Rating "4" if the code can be decoded, otherwise 0".
Axial nonuniformity	Float	Ratio of the module size in horizontal and vertical direction.
Grid nonuniformity	Float	Orientation of the modules relative to the specific symbol grid.
Unused error correction	Float	Error of the code and share of the available error correction mechanisms to successfully decode the code.
Mean light	Float	Assessment of the image quality, calculated via the medium grey-scale value of the centres of the bright DataCode modules. The values are in the range 0.0 (0 %) to 1.0 (100 %) of the full grey-scale range (255 for byte images).
Reflectance margin	Float	Assessment of the amplitude between the DataCode modules.
Print growth	Float	Ratio dark/light modules in the alternating pattern.
Contrast uniformity	Float	Smallest numerical value for the modulation in the entire code.
Aperture	Float	Size indication of the synthetic aperture in relation to the module size of the symbol. The aperture is used to create the reference grey-scale image which is required for the quality assessment.
Format information (mqr/qr only)	Float	Assessment of the modules containing the format information.

Outputs "Quality grading"	Number format	Description
Version information (mqr/qr only)	Float	Assessment of the modules containing the version information.

The logic block [Quality grading] has the following outputs for 2D code types and the quality standard [SEMI T10]:

Outputs "Quality grading"	Description	Number format	Example	Example Description
P1 row	Corner 1 position Y coordinates	Float	01250136	Y=136
P1 column	Corner 1 position X coordinates	Float	01250136	X=125
P2 row	Corner 2 position Y coordinates	Float	00440612	Y=612
P2 column	Corner 2 position X coordinates	Float	00440612	X=44
P3 row	Corner 3 position Y coordinates	Float	01230125	Y=125
P3 column	Corner 3 position X coordinates	Float	01230125	X=123
P4 row	Corner 4 position Y coordinates	Float	00030065	Y=65
P4 column	Corner 4 position X coordinates	Float	00030065	X=3
Rows	ECC200 N (rows)	Float	0010	ECC200 rows=10
Columns	ECC200 M (columns)	Float	0010	ECC200 columns=10
Symbol Contrast	The value for symbol contrast designates the contrast between light and dark classified symbol pixels in percent of the full grey-scale value range (255 for byte images).	Float	0089	Contrast: 8.9%
Symbol Contrast SNR	Symbol contrast SNR is the corresponding signal-to-noise ratio. If the value is infinite, 'N/A' is returned.	Float	0311	Ratio of 3.11
Horizontal Mark Growth	Module width relative to the sum of light and dark modules, in percent	Float	0415	Value of 41.5%
Vertical Mark Growth	Module height relative to the sum of light and dark modules, in percent	Float	0325	Value of 32.5%
Data Matrix Cell Width	Average module height	Float	0020	Average cell height = 20
Data Matrix Cell Height	Average module width	Float	0019	Average cell width = 19
Horizontal Mark Misplacement	Misplacement in horizontal direction, in percent	Float	0152	Value of 15.2%
Vertical Mark Misplacement	Misplacement in vertical direction, in percent	Float	0178	Value of 17.8%
Cell Defects	Percentage of symbol pixels incorrectly classified	Float	0485	Value of 4.5%
Finder Pattern Defects	Percentage of finder pattern pixels incorrectly classified	Float	0237	Value of 23.7%
First Unused Error Correction	Unused capacities for error correction, in percent	Float	0666	Value of 66.6%

**Function [Model overview]**

Function [Model overview]: The status of all ROI groups and the decoding status are provided. The logic block has no settings. The logic block has the following outputs:

Outputs "Model overview"	Number format	Description
All groups passed	bool	The status of the ROI groups is provided.
Decoding status	numerical	The following states of the selected model are provided: <ul style="list-style-type: none"> <li>• "0": The model was not completely executed.</li> <li>• "1": The model was completely executed.</li> <li>• "2": The model is not executed due to a timeout.</li> <li>• "3": The model is executed incompletely due to unknown errors.</li> </ul>

**Function [ROI group]**

Function [ROI group]: The status of a certain ROI group is provided. The logic block has the following settings:

[ROI group 0]	The ROI group is selected.
---------------	----------------------------

The logic block [ROI group] has the following outputs:

All codes found	bool	The status "All codes found" or "All codes not found" is provided.
Decoding status	numerical	The following states of the selected ROI groups are provided: <ul style="list-style-type: none"> <li>• "0": The ROI group has not yet been completely executed.</li> <li>• "1": The ROI group has been completely executed.</li> <li>• "2": The ROI group is not executed due to timeout.</li> <li>• "3": The ROI group is not completely executed because of an unknown error.</li> </ul>
Found codes	numerical	The number of found codes is provided.
Searched codes	numerical	The number of searched codes is provided.

**9.6.11 Description of the logic block "Application result"**

The area "Application result" contains the following logic block:

Application results	bool	The logic block provides the status of the models contained in the application. The status "All models found" or "All models not found" is provided.
---------------------	------	--

## 9.6.12 Description of the logic blocks "String operations"

The area "String operations" contains the following logic blocks:

Logic block	Number format on the input	Number format on the output	Description
Fixed string	-	alphanumeric	Provides an adjustable character string which is used for operations with character strings.
PCIC_INPUT_STRING	-	alphanumeric	Provides an adjustable character string which is used for operations with character strings. The character string can be changed during the runtime with the command "J" (→ Operating instructions supplement - Interface description).
Equal strings	alphanumeric	bool	Compares the character string on both inputs in view of identical content: <ul style="list-style-type: none"> <li>• "a==b" = "1": The character strings are identical.</li> <li>• "a!=b" = "1": The character strings are not identical.</li> </ul>
Equal bytes	byte array	bool	Compares the bool data on the inputs in view of identical content: <ul style="list-style-type: none"> <li>• "a==b" = "1": The bool data is identical.</li> <li>• "a!=b" = "1": The bool data is not identical.</li> </ul> Currently, the inputs are only connected with the output "Code content (raw)" of the logic block "Code detail".
Match regex	alphanumeric	alphanumeric	Applies a regular expression (regex) to the character string on the input. If an expression is found, the output "is a match" provides a boolean "1". The found expression is provided on output "match string". Partial results of the regular expression are provided via the outputs "capture strings 1-4". <p>Example:</p> For "\b([0-9]{4})\b" the result is "True", if the code has exactly 4 digits.
Match pattern	alphanumeric	bool	Searches a pattern in the input string. Wildcards such as "*" and "?" are accepted for the pattern (example: "*.png"). Contains the input string of the pattern, is provided on the output of a boolean "1".
Split by delimiter	alphanumeric	alphanumeric	Searches the delimiter in the character string. The character string is split at the positions of the delimiter. The split string of characters is provided one after the other on the 7 outputs without the delimiter. <p>If the character string is split in more than 7 segments on the input, the output "remainder" provides the segments &gt; 7 with delimiter.</p>
Split string at position	character string: alphanumeric, position: numerical	alphanumeric	Splits a character string at a certain position. The split character string is provided on the outputs.
Concatenate	alphanumeric	alphanumeric	Concatenates up to 7 character strings, optionally with a delimiter. The character string and the optional delimiter are provided via the logic blocks "Fixed string", for example.
Select	bool / alphanumeric	alphanumeric	If there is a boolean "0" on the input "Switch (0/1)", the character string is provided on the input "Option 0". <p>If there is a boolean "1" on the input "Switch (0/1)", the character string is provided on the input "Option 1".</p>
Output string	alphanumeric	-	Saves the received character string via the input. Up to 10 logic blocks "Output string" are available. The content of the logic blocks is retrieved via the process interface 9.7.5 Insert data package).

### 9.6.13 Description of the logic blocks "Arithmetic"

The area "Arithmetic" contains the following logic blocks:

Logic block	Number format on the input	Number format on the output	Description
DIFF	numerical	numerical	The signals on the inputs are subtracted. The two outputs provide the result with different signs.
ADD	numerical	numerical	The signals on the inputs are added.
COUNT	bool	numerical	The signals on the inputs are added. The boolean values on the input are treated as numerical values.
Min max value	numerical	numerical	The minimum and maximum values are determined on the basis of the signals on the inputs.
Fixed value	–	numerical	A floating point number is set as a fixed value. The fixed value is provided and can be used for the logic blocks "DIFF" and "ADD" (for example to set an offset).

### 9.6.14 Description of the logic blocks "Digitalisation"

The area "Digitalisation" contains the following logic blocks:

Logic block	Number format on the input	Number format on the output	Description
Check min quality	numerical	bool	The quality grading value on the input is compared with an adjustable comparison value. For example, "A-D" or "4-0" can be set as comparison value. If the quality grading value is better or equal, "1" is provided on the output.
Comparator	numerical	bool	The signals on the inputs are compared to each other. Signals on the outputs: <ul style="list-style-type: none"> <li>• "1": The relation displayed in the output name applies.</li> <li>• "0": The relation displayed in the output name does not apply.</li> </ul>

### 9.6.15 Description of the logic blocks "Logical functions"

The area "Logical functions" contains the following logic blocks:

Logic block	Number format on the input	Number format on the output	Description
AND	bool	bool	The signals on the inputs are compared to each other. Signals on the output: <ul style="list-style-type: none"> <li>• "1": All signals on the inputs are "1".</li> <li>• "0": Minimum one signal on the inputs is "0".</li> </ul>
OR	bool	bool	The signals on the inputs are compared to each other. Signals on the output: <ul style="list-style-type: none"> <li>• "1": Minimum one signal on the inputs is "1".</li> <li>• "0": All signals on the inputs are "0".</li> </ul>
NOT	bool	bool	The signal on the input is inverted. Signals on the output: <ul style="list-style-type: none"> <li>• "1": The signal on the input is "0".</li> <li>• "0": The signal on the input is "1".</li> </ul>



### 9.6.16 Description of the logic blocks "Output"

The area "Output" contains the following logic blocks:

Logic block	Number format on the input	Description
DIGITAL_OUT1	bool	The digital output is switched with or without limited pulse duration. The digital outputs have the following settings: <ul style="list-style-type: none"> <li>• "Static": The digital output is switched without limited pulse duration (recommended setting).</li> <li>• "Pulsed": The digital output is switched with a limited pulse duration (<math>\geq 10</math> ms).</li> </ul>
DIGITAL_OUT2	bool	
Virtual pins bytes 1-8	bool	The virtual pins are memory areas to transfer the data from the logic area to an interface. A virtual pin consists of an 8-bit order. The 8 virtual pins are arranged in sequence to maximum 64 boolean values and provided via an interface ( $\rightarrow$ 9.7 Interfaces). Non-assigned virtual pins provide a boolean "0".

UK

### 9.6.17 Description of the logic blocks "Pin Events"

The area "Pin Events" contains the following logic blocks:

Logic block	Number format on the output	Description
Ready for trigger	bool	The device is ready for trigger to capture a new image.
Error	bool	The device has found an error.
PCIC O-command	bool	The digital output is switched to "High" or "Low" via the process interface with the "o" command.

### 9.6.18 Description of the logic blocks "Statistics"

The area "Statistics" contains the following logic blocks:

Logic block	Number format on the input	Description
State definition: pass/fail	bool	The result of an application is provided: <ul style="list-style-type: none"> <li>• "1": The application was successfully executed.</li> <li>• "0": The application was not successfully executed.</li> </ul> The result is written in the service report and is available for statistical calculations.

### 9.6.19 Example 1 of "Compare reference code"

A digital signal is provided in the output logic if the device detects a reference code.

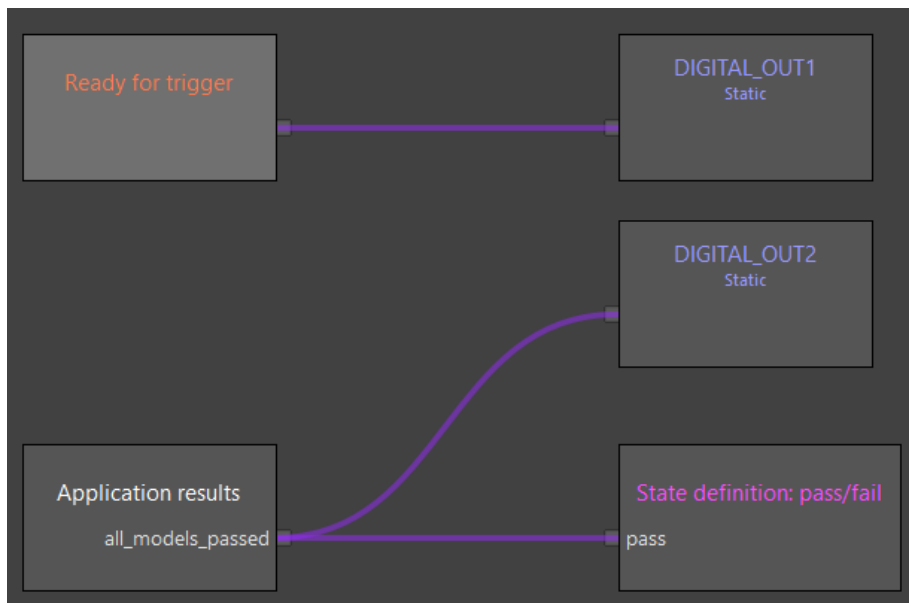

If the model set in the module "Application results" detects the code, the module "DIGITAL\_OUT2" provides the signal "High". If no code is detected, the module "DIGITAL\_OUT2" provides the signal "Low".

### 9.6.20 Example 2 of "Compare reference code"

A digital signal is provided in the output logic if two character strings are identical.

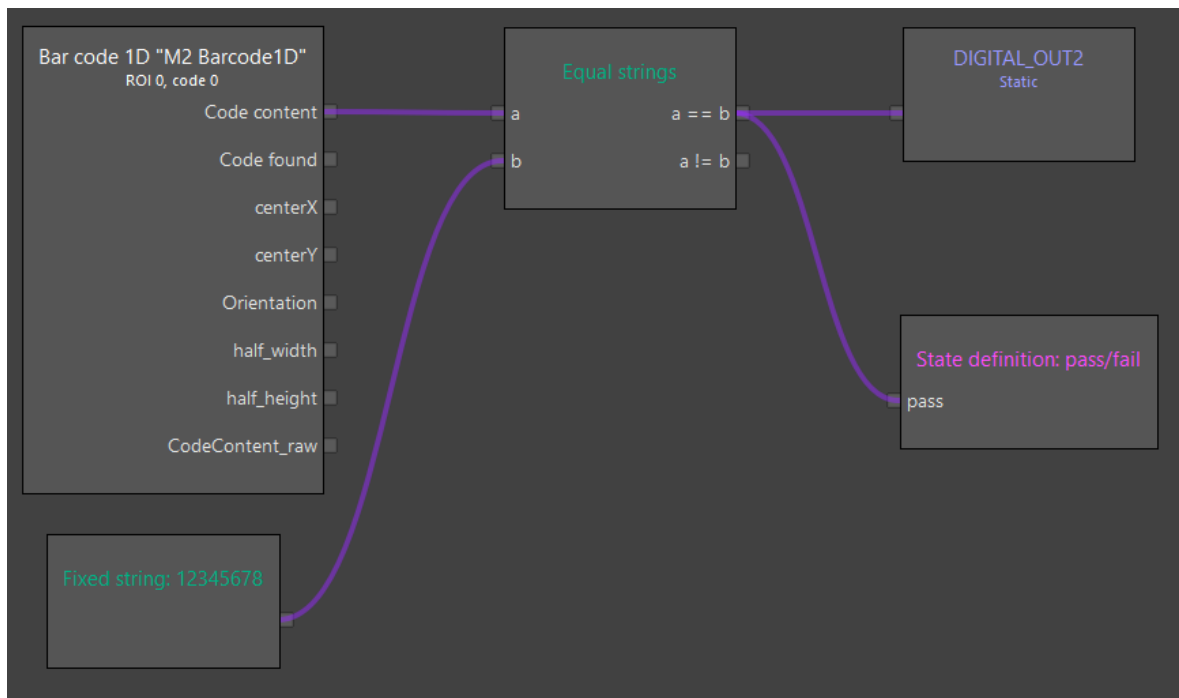

If the code content of the set model is identical with the character string in the module "Fixed string", the module "DIGITAL\_OUT2" provides the signal "High". If no code is detected, the module "DIGITAL\_OUT2" provides the signal "Low".

### 9.6.21 Example 3 of "Compare reference code"

A digital signal is provided in the output logic if two character strings are identical. One of the character strings can be adapted via the process interface.

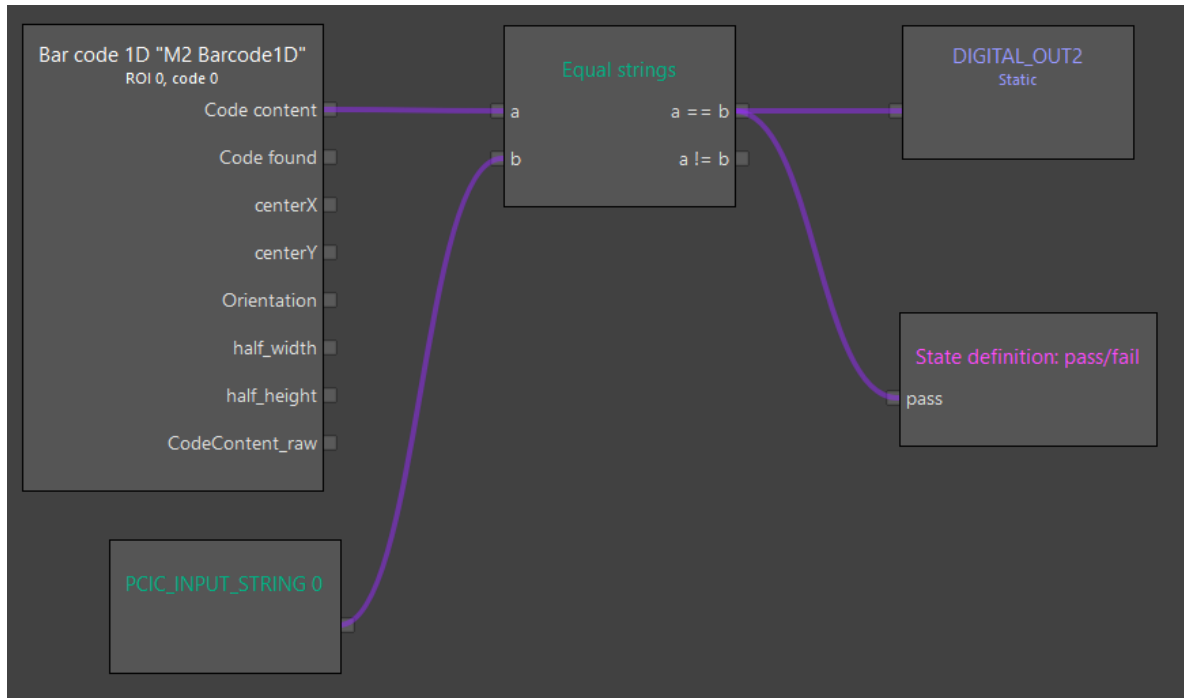

If the code content of the set model is identical with the character string in the module "PCIC\_INPUT\_STRING0", the module "DIGITAL\_OUT2" provides the signal "High". If no code is detected, the module "DIGITAL\_OUT2" provides the signal "Low".

The module "PCIC\_INPUT\_STRING0" is addressed with the "j command" via the process interface.



The "j command" is described in the document "Operating instructions supplement - Process interface".

UK

## 9.7 Interfaces

The function "Interfaces" configures the interfaces of the selected application. Data packages are defined which are sent via the interface.

► Click .

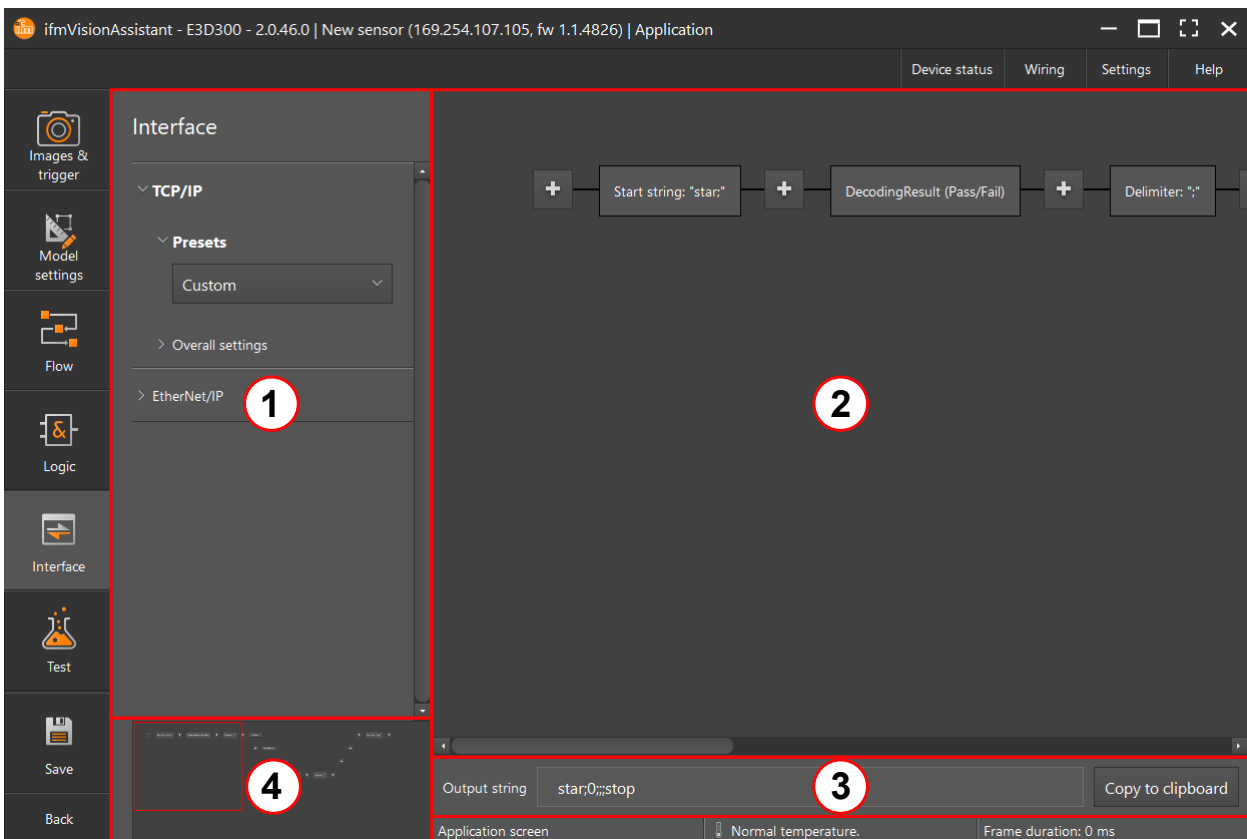

- ① Settings (→ 9.7.1 Settings)
- ② Main area (→ 9.7.2 Main area)
- ③ Output string (→ 9.7.3 Output string)
- ④ Overview area (→ 9.7.4 Overview area)

### 9.7.1 Settings

The area "Settings" contains the following operating elements:

Operating element	Name	Description
<b>TCP/IP / EtherNet/IP / PROFINET</b>		
[Presets]	Presets	Sets sets of preset data packages. The sets are directly used or adapted. An adapted set is saved as preset "Custom".
<b>Overall settings</b>		
	Default value	Restores the default value.
[Data encoding]	Data encoding	Sets the data encoding: ASCII or binary.
[Precision]	Precision	Sets the number of decimal places.
[Display format]	Display format	Sets the display format: <ul style="list-style-type: none"> <li>• "Fixed": fixed-point number</li> <li>• "Scientific": exponential</li> </ul>

Operating element	Name	Description
[Decimal separator]	Decimal separator	Sets the decimal separator. The decimal separator is a 7-bit character (e.g. ".").
[Base]	Base	Sets the output format: <ul style="list-style-type: none"> <li>• "binary": base 2</li> <li>• "octal": base 8</li> <li>• "decimal": base 10</li> <li>• "hex": base 16</li> </ul>
[Width]	Width	Sets the minimum total length of the value.
[Numericfill]	Numericfill	Sets the values of non-used bits: <ul style="list-style-type: none"> <li>• "on": Each non-used bit is assigned a boolean "0" and positive values are preceded by a plus sign.</li> <li>• "off": Bits which are not used remain blank.</li> </ul>
[Fill]	Fill character	Sets the fill character.
[Alignment]	Alignment	Sets the alignment of the value within the defined bit width: <ul style="list-style-type: none"> <li>• "Left"</li> <li>• "Right"</li> </ul>
[Byte order]	Byte order	Sets the byte order: <ul style="list-style-type: none"> <li>• "little endian": least significant byte of a boolean value at the first position or at the lowest memory address.</li> <li>• "big endian": most significant byte of a boolean value at the first position or at the lowest memory address.</li> <li>• "network byte order": byte order specified by the network protocol.</li> <li>• "bus depending order": byte order specified by the fieldbus.</li> </ul>

UK

### 9.7.2 Main area

The data packages of the interface are set in the main area. The data packages are displayed as rectangles. The data blocks are connected via dashed connecting lines. The data is sent from left to right in the order of the data blocks.

### 9.7.3 Output string

The output string is a character string which is changed with the data packages in the main area. Depending on the selected data encoding in the area "Overall settings", the output string is displayed as ASCII or bool code.

The button [Copy to clipboard] copies the output string to the clipboard.



The output string cannot be directly changed. The output string is changed via the data packages in the main area (→ 9.7.2 Main area).

### 9.7.4 Overview area

The overview area displays a reduced overview of the main area. The red frame is shifted using the mouse. Therefore, the data packages are displayed outside the current main area.

### 9.7.5 Insert data package

A new data package is inserted in the main area at the positions marked with :

- ▶ Select an interface in the settings (→ 9.7.1 Settings).
- ▶ Click .
- > A menu with the possible data packages is displayed. The content of the menu depends on the position of the new data package.
- ▶ Select a data package.
- > Available data packages:

Menu element	Description
<b>General</b>	
[Start string]	Adjustable character string for starting a data transfer.
[End string]	Adjustable character string for ending a data transfer.
[User-driven input]	Adjustable character string within data transfer.
[Index of active application]	Index of the active application
[Application decoding time [ms]]	Evaluation time of the application in [ms]
<b>Logic layer</b>	
[Reading result (pass/fail)]	Reading result of the logic block "Status definition: pass/fail" (→ 9.6.18 Description of the logic blocks "Statistics")
[Number of bytes of output strings 0-9]	Size in bytes of the content of the logic block "Output string" (→ 9.6.12 Description of the logic blocks "String operations").
[Output strings 0-9]	Content of the logic block "Output string" (→ 9.6.12 Description of the logic blocks "String operations").
Digital output	Bit order with the values at the digital outputs.
Virtual out	8-byte order with the values at the inputs of the virtual pins.
<b>Application results</b>	
[ImagesSize]	Number of the images defined for the application.
[Images]	The captured images are provided as JPEG one after the other.
[ModelsSize]	Number of the images created for the application.
[Models]	<p>The data of the defined models is provided one after the other. The data package is displayed as a program loop. The content of the program loop also consists of data packages which can be selected separately:</p> <ul style="list-style-type: none"> <li>• "Model ID": The "Model ID" consists of a consecutive number (0-999) in the order in which the models were defined. After 999 IDs have been assigned in an application, the IDs of deleted models are assigned again.</li> <li>• "ModelDecodingStatus": decoding status of the model (→ 9.6.10 Description of the logic blocks "Model results")</li> <li>• "Model: number of codes searched": number of the searched codes</li> <li>• "Model: number of codes found": number of the codes found</li> <li>• "Model Pass/Fail": status definition pass/fail (→ 9.6.18 Description of the logic blocks "Statistics")</li> <li>• "Number of GroupResults": number of the ROI groups in the model (→ 9.6.10 Description of the logic blocks "Model results").</li> <li>• "Result": result of the ROI groups</li> <li>• "User-driven input": adjustable character string</li> <li>• "Delimiter": delimiter to split data packages</li> </ul>
[Delimiter]	delimiter to split data packages

### 9.7.6 Show and hide loops

The data package "Models" consists of several data packages which are connected via loops. Depending on the ROIs contained, this loop is passed through several times.

A loop can be shown or hidden:

- ▶ Click the data package [Models].
- > Depending on the status, the loop is shown or hidden.

### 9.7.7 Set data package

Some data packages can be set.

Set a data package:

- ▶ Click the data package.
- ▶ Click .
- > The settings are applied at once.

### 9.7.8 Delete data package

Delete a data package:

- ▶ Click the data package.
- ▶ Click .
- > The data package is deleted.

### 9.7.9 Example for "Provide overall quality"

In the example, the data packages were configured such that the overall quality is provided via the interface.

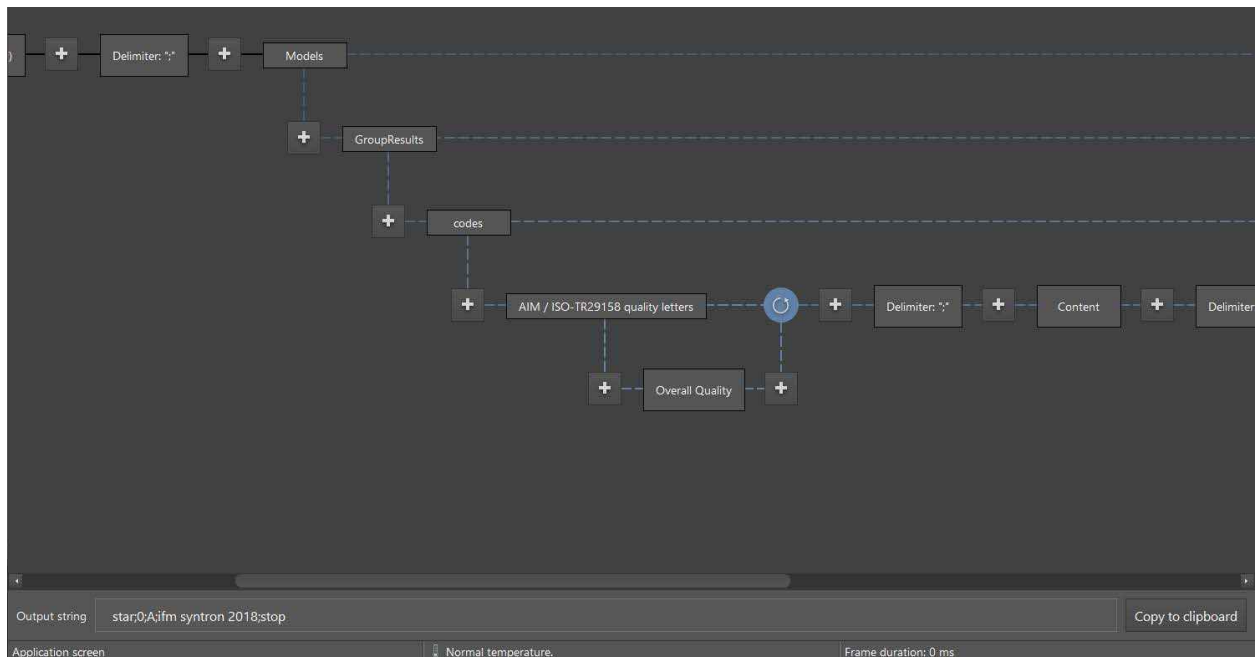

## 9.8 Test

The function "Test" records statistical data on the selected application. During the test, the current states of the device are displayed.

► Click .

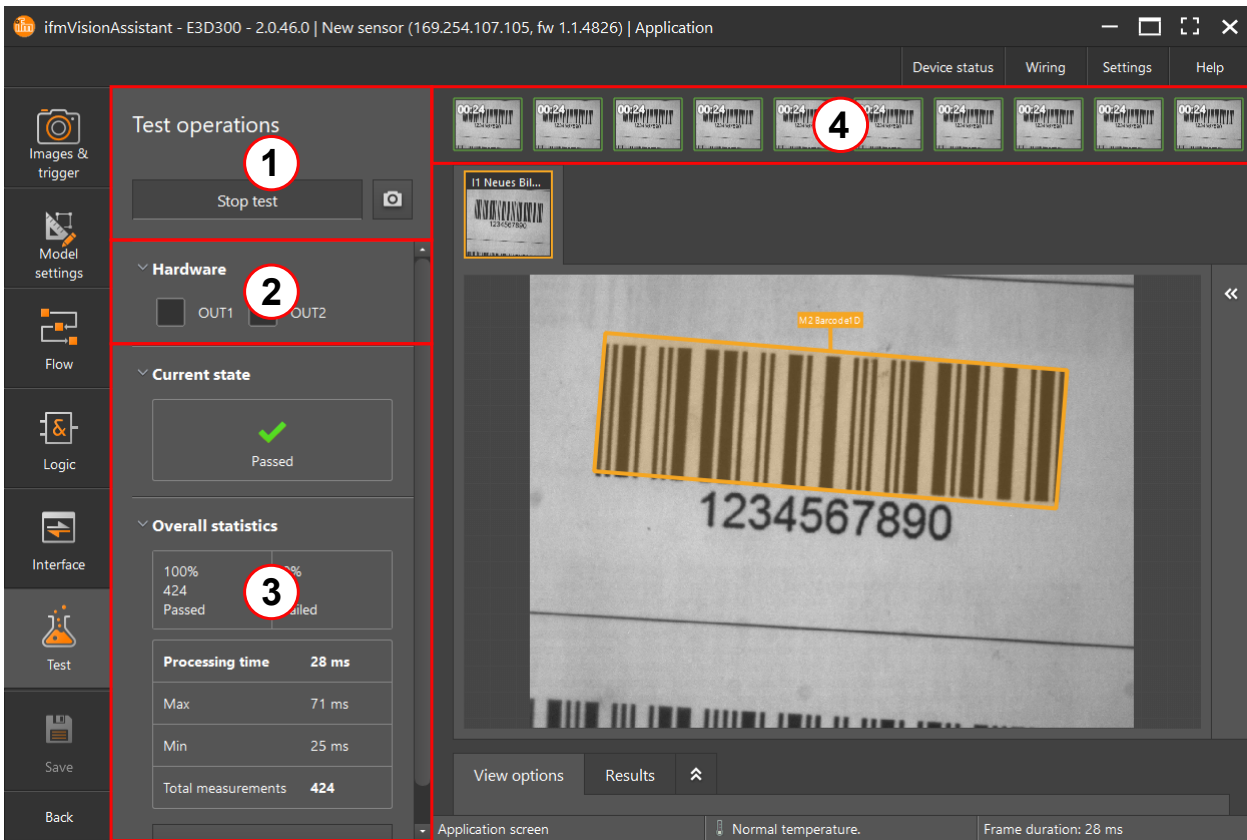

- ① Buttons [Start test], [Stop test] and [Force trigger]
- ② Status of the digital outputs OUT1 and OUT2
- ③ Overall statistics
- ④ Test images

### 9.8.1 Start test

Start the test:

► Click [Start test].

> The test starts image capture according to the setting "Trigger mode".



The test starts automatically after the function "Test" has been activated.

If the image is captured discontinuously, a trigger can be forced manually:

► Click .

> A trigger is forced.



### 9.8.2 Stop test

Stop the test:

- ▶ Click [Stop test].
- > The test is stopped.

### 9.8.3 Test images

Image capture generates test images while a test is active. The test images are displayed above the live image: ④. The test images are chronologically sorted. The most current test image is on the very left.

Additional information is saved with each test image:

- status of the digital outputs OUT1 and OUT2
- overall statistics
- capture time as from test start in minutes:seconds

### 9.8.4 Show test image

Show a test image:

- ▶ Click [Stop test].
- ▶ Click a test image ④.
- > The test image is displayed enlarged in the area "Live image".
- > The states of the digital outputs and the overall statistics are displayed at the time the test image is captured.



Several clicks on the reduced test image ④ above the live image changes between

- the selected test image and
- the test image captured last.

### 9.8.5 Overall statistics

The overall statistics acquires data on the

- number of detected and non-detected codes
- evaluation time of the test images
- number of the total measurements



The overall statistics acquires data after the function "Test" has been activated.

### 9.8.6 Reset overall statistics

Reset the overall statistics:

- ▶ Click [Reset all statistics]
- > The overall statistics is reset.

## 10 Device set-up

The device set-up configures the following areas of the device:



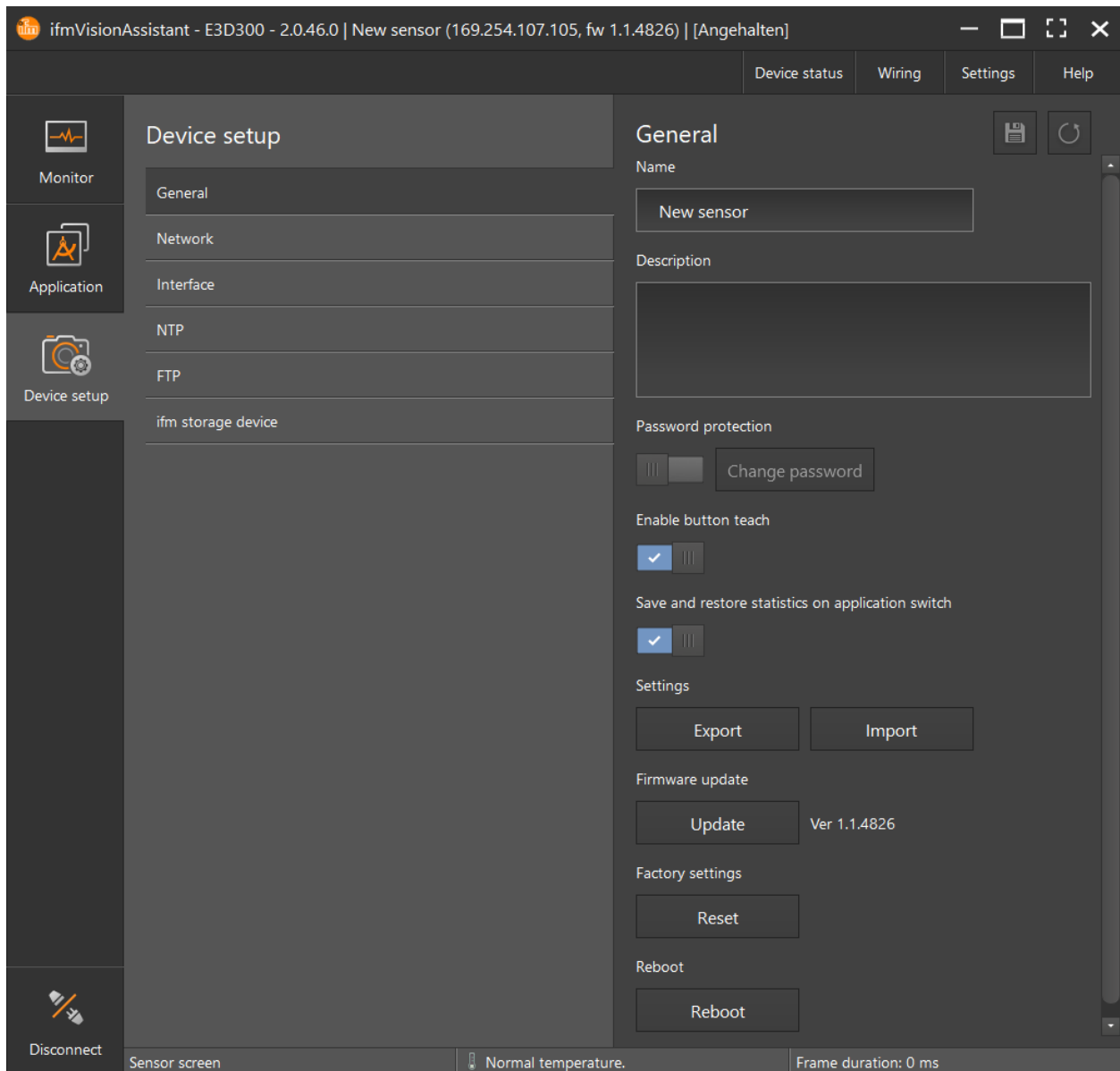

- General (→ 10.1 General)
- Network (→ 10.2 Network)
- Interface (→ 10.3 Interfaces)
- NTP (→ 10.4 NTP)
- FTP (→ 10.5 FTP)
- ifm storage device (→ 10.6 ifm storage device)

► Click .



## 10.1 General

The area [General] contains the following operating elements:

Operating element	Name	Description
	Save change	Saves the changes.
	Reject change	Rejects the changes and restores the original status.
[Name]	Name	Changes the name of the device.
[Description]	Description	Changes the description of the device.
[Change password]	Password protection	Activates the password protection. With active password protection, the following areas are locked: <ul style="list-style-type: none"> <li>• "Application",</li> <li>• "Device setup",</li> <li>• pushbutton teach on the device.</li> </ul> The areas are unlocked with the password. The area "Monitoring" is independent of the password protection and can always be accessed.
Enable button teach	Enable button teach	Activates teaching via button. When button teach is activated, the device can be directly taught by means of the button (→ Operating instructions).
[Save and restore statistics on application switch]	Save and restore statistics	If the function is switched on, the statistics of an application are saved before switching to another application. If there are statistics saved for an application, they are restored.
[Export]	Export settings	Exports the settings and applications to a file.
[Import]	Import settings	Imports the settings and applications from a file.
[Update]	Update firmware	Updates the firmware of the device.  If the firmware update fails, an error message is displayed (→ 11.2.1 Firmware update).
[Reset]	Restore factory settings	Restores the factory settings and deletes all settings and applications.  The settings and applications are deleted when the factory settings are restored. ▶ Export the settings before restoration.
[Reboot]	Reboot	Reboots the device.  After reboot, the ifm Vision Assistant re-establishes the connection to the device.





The settings have to be saved:

▶ Click .

## 10.2 Network

In the area [Network], the network connection of the device is set. The area [Network] contains the following operating elements:

Operating element	Name	Description
	Save change	Saves the changes.
	Reject change	Rejects the changes and restores the original status.
[DHCP]	DHCP	Activates the automatic assignment of the network settings (DHCP). With activated DHCP, the input fields [IP address], [Subnet mask] and [Gateway] are not available.
[IP address]	IP address	Changes the IP address of the connected device (default value: 192.168.0.69).  The device must be rebooted if the EtherNet/IP or PROFINET interface is used after a change of the IP address. If TCP/IP is used, it is not necessary to reboot the device.
[Subnet mask]	Subnet mask	Changes the subnet mask of the connected device (default value: 255.255.255.0).
[Gateway]	Gateway	Changes the gateway of the connected device (default value: 192.168.0.201).
MAC address	MAC address	Displays the MAC address of the connected device.









The settings have to be saved:

► Click .

## 10.3 Interfaces

In the [Interface] area, the interfaces and digital outputs are set. The area [Interface] contains the following operating elements:

Operating element	Name	Description
	Save change	Saves the changes.
		Reject change
[Process interface version]	Process interface version	Sets the version of the process interface protocol. Currently only version "V3" is supported.
[PCIC-Port]	PCIC-Port	Sets the TCP/IP port for the data of the process interface with a socket connection. Default value: 50010.  In the event of connection problems, activate the TCP/IP port in the firewall.
[PCIC TCP/IP scheme auto update]	PCIC TCP/IP scheme auto update	If "PCIC TCP scheme auto update" is off, the PCIC data output of the previous application remains active when the active application is changed (→ Operating instructions). Only if the connection to the device is separated, will the PCIC data output change. If "PCIC TCP scheme auto update" is on, the corresponding PCIC data output is activated when the active application is changed (→ Operating instructions).
[Active fieldbus]	Active fieldbus	Sets the fieldbus for the communication with connected controllers.  Only one fieldbus can be active at a time. The setting has an effect on all applications.
[Profinet device name]	Profinet device name	Sets the name of the device if PROFINET is used.  The operating element is displayed if [Active fieldbus] is set to [Profinet].
[Producing size]	Producing assembly size	Sets the size of the "Producing assembly" memory, if <ul style="list-style-type: none"> <li>the output buffer of the PLC is too small,</li> <li>the length of the data to be sent is to be limited.</li> </ul> Value range: 16-450 bytes
[Consuming size]	Consuming size	Sets the size of the "Consuming assembly" memory, if <ul style="list-style-type: none"> <li>the input buffer of the PLC is too small,</li> <li>the length of the data to be sent is to be limited.</li> </ul> Value range: 8-450 bytes
[Output logic]	Output logic	Sets the output logic of the digital outputs of the device: <ul style="list-style-type: none"> <li>PNP: switch positive potential to the output</li> <li>NPN: switch ground to output</li> </ul>
[IO debouncing]	[IO debouncing]	Activates the debouncing of the trigger. Then a signal has to be present for at least 3 ms to be detected as trigger signal. Shorter signals are ignored.
[External illumination]	External illumination	Activates the external illumination. The external illumination is described in the operating instructions.  If the external illumination is activated, the output DIGITAL_OUT2 is reserved for the external illumination. The output is no longer available as logic module (→ 9.6.16 Description of the logic blocks "Output").  If the output DIGITAL_OUT2 is already used as logic block, the operating element [External illumination] is grayed out and cannot be used.



The settings have to be saved:

▶ Click .

## 10.4 NTP

In the [NTP] section, the clock of the device is set. The clock is synchronised via the Network Time Protocol (NTP).



In the event of connection problems, activate port 123 in the firewall.



The clock is not buffered by a battery. If the current supply fails, the clock is reset.

The area [NTP] contains the following operating elements:

Operating element	Name	Description
	Save change	Saves the changes.
	Reject change	Rejects the changes and restores the original status.
[Activate NTP]	NTP server	Activates the Network Time Protocol. Default value: deactivated.
[IP]	IP address	<p>Sets the IP address of the NTP server. The date and the time are synchronised with the NTP server. Several NTP servers can be set. Besides the IP address, the status of the server is displayed:</p> <p> green      The server replied to the last request.</p> <p> red      The server did not reply to the last request.</p> <p> grey      So far no request has been sent to the set NTP server.</p>
	Add NTP server	Adds a connection to the server.
	Delete NTP server	Deletes the connection to the server.
[Max number of requests to NTP servers]	Maximum number of requests to the NTP servers	Sets the maximum number of requests. If the NTP server does not reply within the number of requests, the NTP server will be ignored in future.
[Current time set on device]	Current time set on the device	Displays the time currently used in the device.



The settings have to be saved:

► Click .

## 10.5 FTP

In the [FTP] section, a connection to an FTP server is made. The device sends current images and configurations to the FTP server if certain events occur.











The FT protocol transfers data such as user name and password unencrypted. The data can be read and manipulated by third parties.

- Do not use the user name and the password of the FTP server for other services.
- Restrict the visibility of the FTP server to the local network.
- Do not use the function [FTP] if the FTP server is visible on the internet.



In the event of connection problems, activate ports 20 and 21 in the firewall.

The area [FTP] contains the following operating elements:

Operating element	Name	Description
     [Activate]	Save change	Saves the changes.
	Reject change	Rejects the changes and restores the original status.
	Add FTP server	Adds a connection to the server.
	Rename FTP server	Renames the local designation of the FTP server. Besides the name, the status of the server is displayed:  The server replied to the last request. green  The server did not reply to the last request. red  A connection to the server has not been made, yet. grey
	Delete FTP server	Deletes the connection to the server.
	Activate	Activates the FTP client on the device.
<b>Connect</b>		
[Server IP] [Port]	Server IP address, port	Sets the IP address and the port of the FTP server (default value for the port: 21).
[User] [Password]	User, password	Sets the user name and the password of the FTP server if authentication is required.
<b>Folders</b>		
[Push decoding results]	Transfer decoding results	Activates the transfer of decoding results to the FTP server.
[Path]	Path	Sets the path to transfer the decoding results.
[Push image data]	Transfer image data	Activates the transfer of the image data to the FTP server.
[Path]	Path	Sets the path to transfer the image data.
[Push device and application configuration data]	Transfer device and application data	Activates the transfer of device and application data to the FTP server.
[Path]	Path	Sets the path to transfer the device and application data.
<b>Configuration</b>		
[Passive mode]	Passive mode	Activates the passive mode. The passive mode reduces connection problems in context with a firewall.
[Keep alive]	Keep alive	Activates the keep-alive function. Depending on the configuration, the connection is quickly stopped on the server side. With the keep-alive function, the connection remains active.
[Warranty of data transfer]	Warranty of data transfer	Activates the warranty of data transfer. It is ensured that all data is transferred. If the data is not transferred fast enough, it is possible that <ul style="list-style-type: none"> <li>● image capture is delayed,</li> <li>● the frame rate is reduced.</li> </ul>
[Result types to be pushed]	Result types which are to be pushed	Selects a result type which is transferred to the FTP server.

 The settings have to be saved:

▶ Click .

## 10.6 ifm storage device

In the section [ifm storage device], the ifm storage device is set. The ifm storage device is located behind a service lid in the device. The configuration of the device and error images are saved on the ifm storage device.



The ifm storage device must not be inserted in a PC, notebook or similar.

► Only use the ifm storage device with the devices O215xx.

The contents saved on the ifm storage device is available on a website. The URL of the website is indicated in the area [ifm storage device].



If the device fails due to a defect, the configuration is saved on the ifm storage device and can be quickly transferred to a replacement device (→ "Operating instructions").

The area [ifm storage device] contains the following operating elements:

Operating element	Name	Description
	Save change	Saves the changes.
	Reject change	Rejects the changes and restores the original status.
[Save error images]	Save error images	Activates saving of images to the ifm storage device in case of an error. Default value: deactivated.
[Enable configuration change storage]	Enable configuration change storage	Activates saving of configurations on the ifm storage device. Default value: activated.
[Format storage]	Format storage	Formats the ifm storage device. Formatting cannot be reversed. All data on the ifm storage device is deleted.
[Import latest config from storage]	Import the latest configuration	Imports the configuration saved last on the ifm storage device. After clicking the button, you can choose the parts of the configuration to be imported: <ul style="list-style-type: none"> <li>• Global settings</li> <li>• Network</li> <li>• Application settings</li> </ul> The configuration currently used in the ifm Vision Assistant is overwritten.
[Web interface URL:]	[Web interface URL:]	Displays the URL to the web interface of the ifm storage device. The URL is structured as follows: http://<IP address>/storage/ A click on the URL shows the content of the ifm storage device in the web browser.



The settings have to be saved:

► Click .



## 11 Appendix

### 11.1 Network settings

Below you find a description of how to assign a static IP address to the device. A static IP address is necessary if

- the assignment of a dynamic IP address is not possible due to the network configuration,
- the firmware of the device is to be updated.



The details of the network settings in this document describe the procedure for PCs with the operating system Windows 10.

Changing network settings in a PC requires administrator rights.

The following ports must be open (if necessary, adapt the firewall settings):

- UDP: 3321
- TCP/HTTP: 80 and 8080
- TCP: 50010

► Open [Network and Sharing Centre].

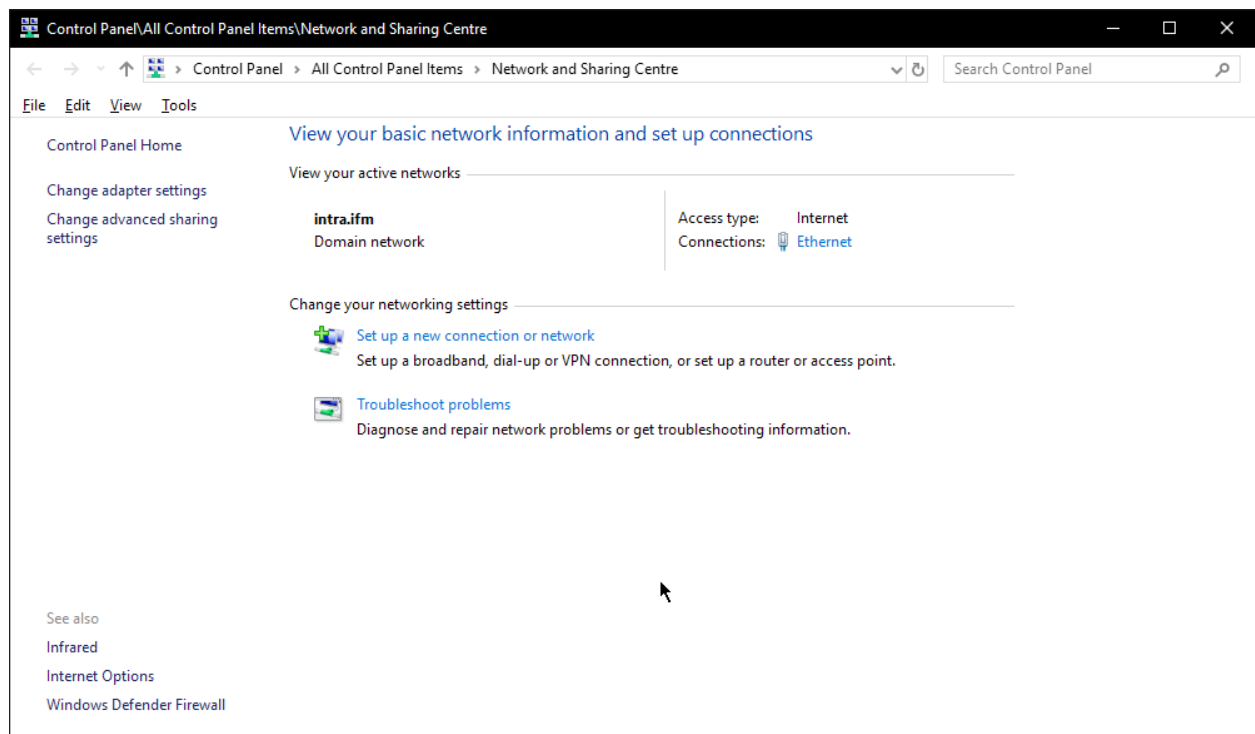

► Click the name of the local network next to [Connections].

> The window "Ethernet Status" opens.

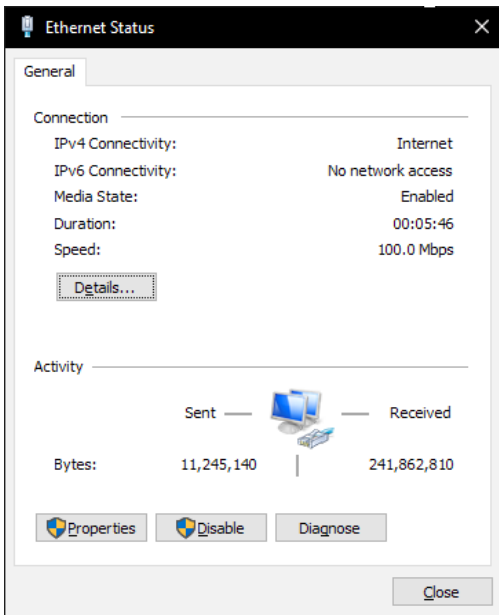

- ▶ Click [Properties].
- > The window "Ethernet Properties" opens.

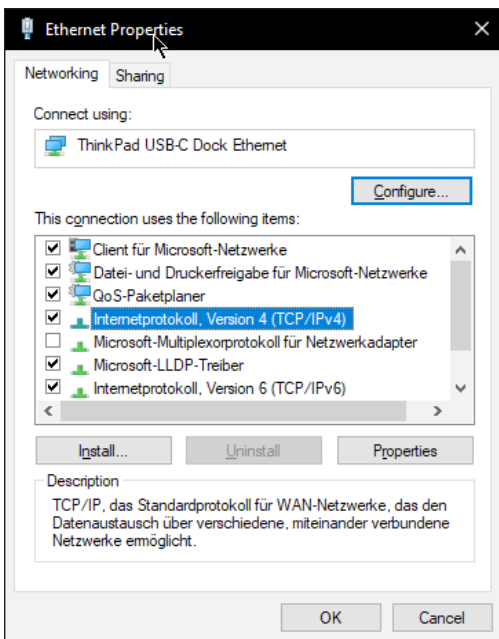

- ▶ Select [Internet Protocol Version 4 (TCP/IPv4)].
- ▶ Click [Properties].
- > The window "Internet Protocol Version 4 (TCP/IPv4) Properties" opens.

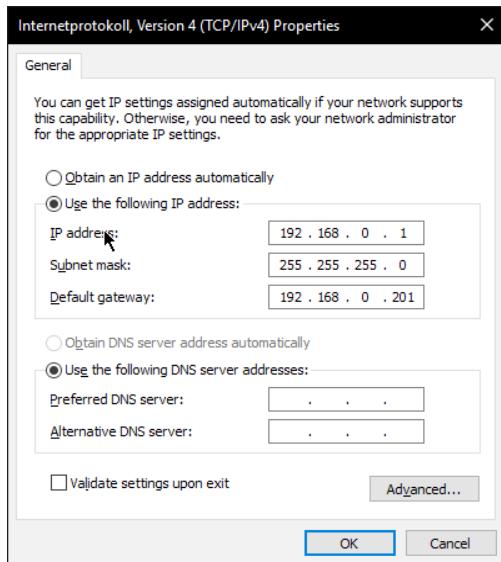





- ▶ Select the menu item "Use the following IP address:".
- ▶ Set the following default values:
  - IP address: 192.168.0.1
  - Subnets: 255.255.255.0
  - Default gateway: 192.168.0.201
- ▶ Click on [OK].

## 11.2 Error messages

### 11.2.1 Firmware update

The following error messages may occur during the firmware update:

Error message	Description
 <p>No firmware update on t... Firmware update is not supported with dynamic IP address. Change to a static</p>	<p>The device is set to a temporary address or to DHCP.</p> <ul style="list-style-type: none"> <li>▶ Change network settings of the device to a static IP address.</li> <li>&gt; After saving the settings, the ifm Vision Assistant establishes the connection automatically.</li> </ul>
 <p><b>Firmware update failed</b> Failed to boot recovery-mode. [120001]</p>	<ul style="list-style-type: none"> <li>▶ Click  on the start screen and reconnect the device.</li> </ul>
 <p><b>Firmware update failed</b> Failed to transfer file to device. [120002]</p>	<ul style="list-style-type: none"> <li>▶ Click the message [Running recovery mode].</li> <li>▶ Click the message [Install another firmware].</li> </ul>
 <p><b>Firmware update failed</b> Installation of the firmware update failed. [120003]</p>	<ul style="list-style-type: none"> <li>▶ Install another firmware.</li> </ul>



With the key combination Ctrl+C, the text of a message is copied to the clipboard. This works with all messages displayed in the ifm Vision Assistant.

## 11.3 Glossary

### **Active application**

The application set to "Active" in the device: This application is running when the device is ready for operation.

### **Application switching**

Application switching is started via the process interface.

### **Operating mode**

Active mode by default if an active application is available on the device. The active application is in the process of being executed.

### **Process interface**

Interface for external hardware: Data can be transmitted or received via the process interface (by a PLC, for example).